



User Guide

HEAT RECOVERY VENTILATORS HRV 60H AND ENERGY RECOVERY VENTILATORS ERV 60H

**Model no.: 41602
(HRV with ports on top)**



VB0072

**Model no.: 41600
(HRV with ports on sides)**



VB0076

**Model no.: 41606
(ERV with ports on top)**



VB0073

**Model no.: 41604
(ERV with ports on sides)**



VB0075

PLEASE READ AND SAVE THESE INSTRUCTIONS.



7 72371 08632 6

06009B rev. B

Congratulations!

You have made an excellent choice! The operating principle of your Heat Recovery Ventilator or Energy Recovery Ventilator will give you personal comfort you have never known before.

We have prepared this User Guide especially for you. Please read it carefully to ensure you obtain full benefit from your unit. Over the coming months, you will increasingly appreciate the feeling of living in a more comfortable house.

Please take note that this manual uses the following symbols to emphasize particular information:

WARNING

Identifies an instruction which, if not followed, might cause serious personal injuries including possibility of death.

CAUTION

Denotes an instruction which, if not followed, may severely damage the unit and/or its components.

NOTE: Indicates supplementary information needed to fully complete an instruction.

We welcome any suggestions you may have concerning this guide and/or the unit, and we would appreciate hearing your comments on ways to better serve you. Please forward all correspondence to us at the address indicated on the product registration card included with this guide.

CAUTION

Make sure at all times that the outside hood is free from any snow during the winter season. It is important to check your unit during a big snow storm, so it doesn't draw in any snow. If this is the case, please operate the unit in the recirculation mode (if available), or turn it OFF for a few hours. Do not use your HRV or ERV during construction or renovation of your house or when sanding drywall. This type of dust may damage your system. Since the electronic control system of the unit is incorporated with a microprocessor, it may not operate correctly because of external noise or very short power failure. If this happens, unplug the unit and wait approximately 10 seconds. Then, plug the unit in again.

Table of contents

1.0 Defrosting Mode	2
2.0 Controls	3-6
2.1 <i>Integrated Control</i>	3
2.2 <i>Optional Main Controls</i>	3-5
2.3 <i>Optional Auxiliary Controls</i>	6
3.0 Maintenance	7-8
3.1 <i>Semi-Annual Maintenance</i>	7-8
3.2 <i>Annual Maintenance</i>	8
4.0 Troubleshooting	9

1.0 Defrosting Mode

When the outside temperature is below -5°C (23°F), recovery (of heat or energy) creates frost in the core.

To maintain its proper operation, the unit is programmed to defrost the recovery core. The defrost frequency varies according to the outside temperature.

During the defrost cycle, the unit shifts to maximum speed and the dampers close. After defrosting, the unit returns to the operating mode selected by the user.

2.0 Controls

2.1 Integrated Control

All units are equipped with an integrated control, located under the unit, in front of the electrical compartment. Use the push button (1) to control the unit. The LED (2) will then shows on which mode the unit is in.

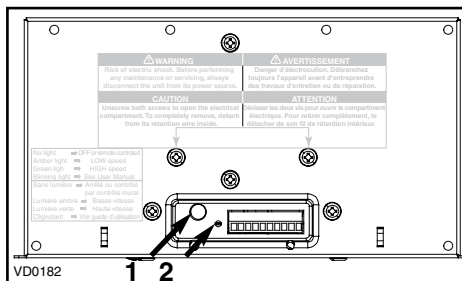

Refer to table below to see how to operate the unit using its integrated control.

PRESS ON PUSH BUTTON	LED COLOR	RESULTS
ONCE	AMBER	UNIT IS ON LOW SPEED
TWICE	GREEN	UNIT IS ON HIGH SPEED
THREE TIMES	NO LIGHT	UNIT IS OFF

If a problem occurs during the unit operation, its integrated control LED (2) will blink. The color of the blinking light depends on the type of error detected. Refer to *Section 4.0 Troubleshooting* on last page for further details.

BOOT SEQUENCE

The unit boot sequence is similar to a personal computer boot sequence. Each time the unit is plugged after being unplugged, or after a power failure, the unit will perform a 30-second booting sequence before starting to operate. During the booting sequence, the integrated control LED will light GREEN or AMBER for 5 seconds, and then will shut off for 2 seconds. After that, the LED will light RED for the rest of the booting sequence. During this RED light phase, the unit is checking and resetting the motorized damper position. Once the motorized damper position is completely set, the RED light turns off and the booting sequence is done.

NOTE: No command will be taken until the unit is fully booted.

2.2 Optional Main Controls

For more convenience, this unit can also be controlled using an optional main control. All the following models can be used, but only one of them can be connected to the unit.

NOTES: 1. The integrated control must be turned OFF to use an optional main control.

2. If an optional auxiliary control is used, if activated, this auxiliary control will override the optional main control.

2.0 Controls (cont'd)

2.2 Optional Main Controls (cont'd)

2.2.1 Lite-Touch Bronze

Activate the push button; the color of the indicator shows the unit operating mode.

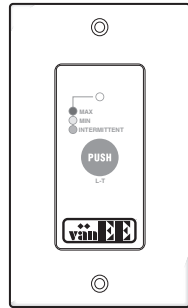

VC0080

COLOR	MODE	SUGGESTED USE
GREEN	INTERMITTENT	SELECT THIS MODE WHEN YOU ARE AWAY FROM THE HOUSE FOR A FEW DAYS. ALSO, WHEN YOU DEEM THE INSIDE AIR IS TOO DRY IN HEATING SEASON, OR TOO HUMID DURING COOLING SEASON. IN THIS MODE, THE UNIT IS OFF FOR 40 MINUTES PER HOUR AND VENTILATES AT MINIMUM SPEED THE REMAINING 20 MINUTES OF THE HOUR.
YELLOW	MIN SPEED VENTILATION	FOR NORMAL DAILY OPERATION.
RED	MAX SPEED VENTILATION	FOR EXCESS POLLUTANTS AND HUMIDITY (PARTIES, ODORS, SMOKE, ETC.).

2.2.2 Simple-Touch Bronze

Activate the push button; the color of the indicator shows the unit operating mode.

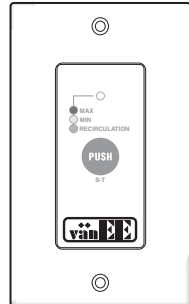

VC0081

COLOR	MODE	SUGGESTED USE
GREEN	RECIRCULATION	USE THIS MODE WHEN YOU DEEM THE INSIDE AIR IS TOO DRY IN HEATING SEASON, OR TOO HUMID DURING COOLING SEASON. IN THIS MODE, THE UNIT STOPS EXCHANGING WITH THE OUTSIDE AND RECIRCULATES INSIDE AIR AT HIGH SPEED.
YELLOW	MIN SPEED VENTILATION	FOR NORMAL DAILY OPERATION.
RED	MAX SPEED VENTILATION	FOR EXCESS POLLUTANTS AND HUMIDITY (PARTIES, ODORS, SMOKE, ETC.)

2.0 Controls (cont'd)

2.2 Optional Main Controls (cont'd)

2.2.3 Bronze

ADJUSTING AIR SUPPLY CONTROL

- 1) **Select speed «MIN» or «MAX»** using slide switch **(A)**.

- When «MIN» (minimum speed) is selected, if the knob **(B)** is set above the click, the unit will exchange in low speed with the outside and if it is set below the click, the unit will exchange on high speed with the outside until the desired humidity level has been reached.

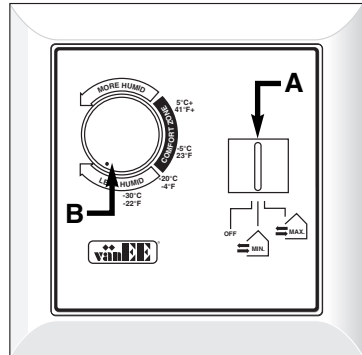

VC0039

- When «MAX» (maximum speed) is selected, the unit will exchange on high speed with the outside either if the knob is set below or above the click.

- 2) To **turn off the unit**, slide the switch at the «OFF» position.

ADJUSTING HUMIDITY CONTROL

Setting during the summer months:

During this period, unless being afflicted with breathing problems, using the humidity control is unnecessary. Set the slide switch to «OFF». (Do not exchange in day time; exchange at night time, if cool outside, or if it is not raining.)

Setting during the fall, winter and spring months: (When severe condensation appears on windows)

- 1) Determine the humidity level in your house (bring the knob **(B)** counterclockwise to its maximum position, then bring it back clockwise slowly until you hear a «click»).
- 2) Set the knob to one line under this temperature level or «click».

CAUTION

Do not select a temperature below -20°C (-4°F). This could lead to excessive dryness in the air causing discomfort for the occupants.

It is possible (and normal) to experience condensation on your windows when drastic changes in temperature happen (for example: -5°C [23°F] to -20°C [-4°F]). In that case, we suggest waiting a few days to allow the situation to stabilize.

2.0 Controls (cont'd)

2.3 Optional Auxiliary Controls

Contrary to the optional main controls, up to 5 optional auxiliary controls can be connected to the same ventilation unit.

2.3.1 20-minute lighted push button

Press once to activate the push button. The unit will operate on high speed for 20 minutes and the indicator will light up. To stop activation before the end of the 20-minute cycle, push one more time. The unit will get back to its previous setting.

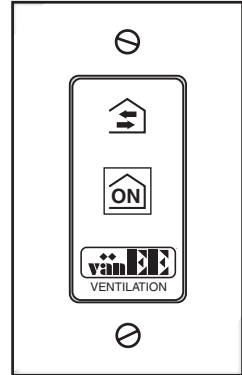

VC0040

2.3.2 60-minute crank timer

This control makes the system operate at high speed for periods varying from 10 to 60 minutes.

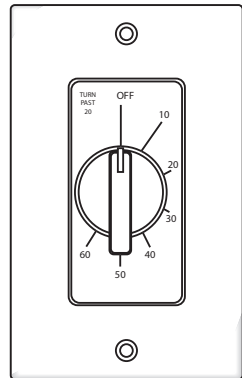

VC0017

2.3.3 Humidity Control

Adjust knob to the desired maximum indoor humidity level.

CAUTION

Do not select a humidity level below 30%. This could lead to excessive dryness in the air causing discomfort for the occupants.

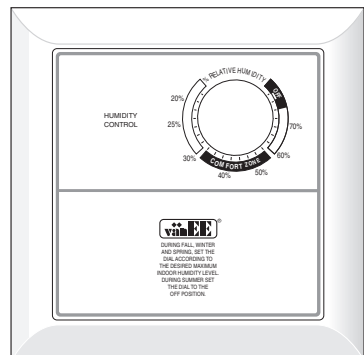

VC0038

3.0 Maintenance

WARNING

Risk of electric shock. Before performing any maintenance or servicing, always disconnect the unit from its power source.

Since this guide covers both HRV and ERV units, top and side ports, the illustrations shown in the maintenance procedures are typical. The following procedures applies for both HRV and ERV units.

Refer to pictures below to identify the inner parts of your unit.

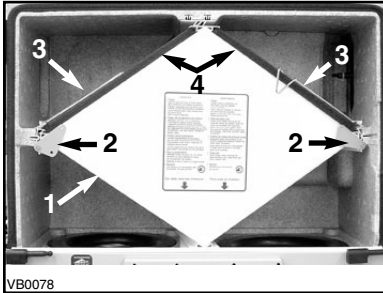

1) HRV core
2) Core retainers
3) Foam filter brackets
4) Foam core filters

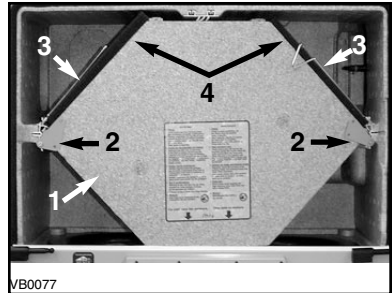

1) ERV core
2) Core retainers
3) Foam filter brackets
4) Foam core filters

3.1 Semi-Annual Maintenance

1. Unplug the unit.

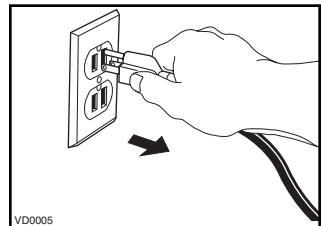

VD0005

WARNING

Be careful before opening the door; water or small debris could fall out. For HRV unit, always wait one minute after disconnecting the unit before opening the door in order to allow water to drain out from the unit.

2. Unlatch the door and open it. Clean the inner side of the door with a damp cloth, then wipe with a dry one. Disengage the door from its hinge by sliding it from left to right and set aside.

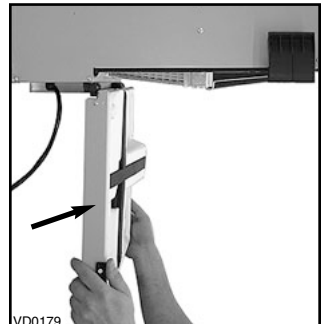

VD0179

3.0 Maintenance (cont'd)

3.1 Semi-Annual Maintenance (cont'd)

WARNING

Always hold the core when rotating the 2 core retainers; failure to do so will cause the core to fall out.

3. Lift both foam filter brackets (1) and remove the foam filters from the core. While holding the core, rotate the 2 core retainers (2) and slide out the core from the unit.

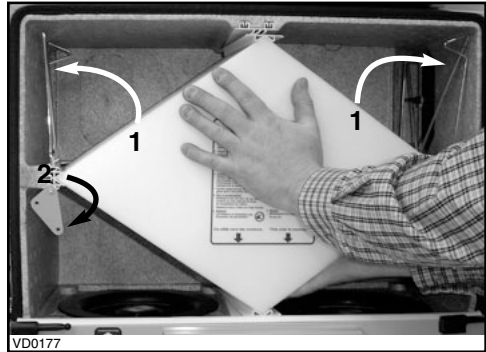

4. Clean the inside walls of the unit with a clean damp cloth, then wipe with a clean dry one.
5. Wash the 2 core filters under hot water with mild soap. Rinse thoroughly and let dry completely before reinstalling on the core.
6. Remove the dust on the core using a vacuum cleaner and a soft brush attachment.

WARNING

Once the core is reinstalled in the unit, always rotate both core retainers to their initial position; failure to do so will cause the core to fall out.

7. Slide the core in the unit. Secure the core by rotating both core retainers to their initial position.

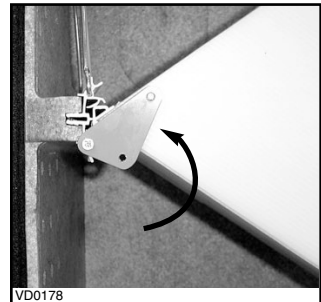

NOTE: Once the core is reinstalled in the unit, the arrows (A) on its sticker label must be pointing towards the unit motors.

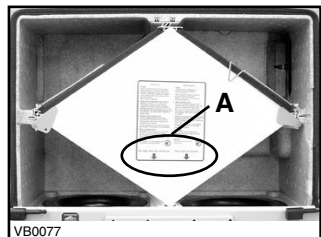

3.0 Maintenance (cont'd)

3.1 Semi-Annual Maintenance (cont'd)

8. Reinstall both foam filters and secure them to the core by pulling down the 2 foam filter brackets. Reinstall the door.
9. Close the door and plug the unit.
NOTE: The unit will return to its previous setting after a 30-second delay for boot sequence.

3.2 Annual Maintenance

Do the same operations as the Semi-Annual Maintenance (*Section 3.1*). Then, clean the exterior hood(s).

4.0 Troubleshooting

TYPE OF PROBLEM	SOLUTION
1. NOTHING WORKS.	<ul style="list-style-type: none">• SEE IF THE UNIT IS PLUGGED IN.• SEE IF THE UNIT IS RECEIVING POWER FROM THE HOUSE CIRCUIT BREAKER.
2. CONDENSATION ON WINDOWS (INSIDE AIR TOO HUMID.)	<ul style="list-style-type: none">• SEE CONTROLS SECTION ON PAGES 3 TO 6.• LEAVE CURTAINS HALF-OPEN TO ALLOW AIR CIRCULATION.• STORE ALL FIREWOOD IN A CLOSE ROOM WITH A DEHUMIDIFIER OR IN A WELL VENTILATED ROOM, OR STORE THE WOOD OUTSIDE.• DO NOT ADJUST THE THERMOSTAT OF YOUR HEATING SYSTEM BELOW 18°C (64°F).
3. INSIDE AIR TOO DRY.	<ul style="list-style-type: none">• SEE CONTROLS SECTION ON PAGE 3 TO 6.• TEMPORARILY USE A HUMIDIFIER.
4. AIR TOO COLD AT THE AIR SUPPLY GRILLE.	<ul style="list-style-type: none">• CHECK IF THE EXTERIOR HOOD IS NOT BLOCKED.• SEE CONTROLS SECTION ON PAGE 3 TO 6.• INSTALL A DUCT HEATER.
5. THE LED OF THE INTEGRATED CONTROL IS BLINKING RED.	<ul style="list-style-type: none">A) THE DOOR IS OPEN AND THE UNIT IS NOT UNPLUGGED. CLOSE THE DOOR AND PRESS ONCE ON THE INTEGRATED CONTROL PUSH BUTTON TO RESET THE UNIT.B) THERE IS A PROBLEM WITH THE EXHAUST MOTOR. THE UNIT IS OFF. CONTACT YOUR INSTALLER.
6. THE LED OF THE INTEGRATED CONTROL IS BLINKING GREEN.	<ul style="list-style-type: none">• THERE IS A PROBLEM WITH THE THERMISTOR. THE UNIT IS STILL WORKING, BUT IS ALWAYS IN DEFROST MODE. CONTACT YOUR INSTALLER.
7. THE LED OF THE INTEGRATED CONTROL IS BLINKING AMBER.	<ul style="list-style-type: none">• THERE IS A PROBLEM WITH THE MOTORIZED DAMPER. THE UNIT IS OFF. FOR A 12-HOUR PERIOD, THE UNIT WILL TRY TO RESET THE DAMPER AT EVERY 20 TO 30 MIN. AFTER 12 HOURS, IF THE PROBLEM IS NOT SOLVED, THE UNIT STOPS TRYING TO RESET DAMPER. CONTACT YOUR INSTALLER.
8. THE INTEGRATED CONTROL PUSH BUTTON DOES NOT WORK.	<ul style="list-style-type: none">• THE 30-SECOND BOOT SEQUENCE IS NOT COMPLETED. SEE INTEGRATED CONTROL ON PAGE 3.

If the problem is still not solved, all your installer or the nearest approved Service Center. Also, you can reach the Customer Service Department at the following phone number: 1 800 567-3855.