

Gold Series

HEAT RECOVERY VENTILATOR

vănEE 2001 HRV Part #45828

114 to 250 CFM (0.3 in. w.g.)
108 to 235 CFM (0.4 in. w.g.)



VB0024

FOR RENOVATION & CUSTOM BUILT HOUSES

Designed for homeowners seeking best performance, added value, quality and a longer warranty.

Recognized for its unsurpassed quality and superior craftsmanship, the Gold Series reflects a new level of exceptional performance. It is guaranteed to satisfy the homeowner looking for durability, reliability and performance. The Gold Series: the best of the vănEE experience.

Solid Performances

- Best heat recovery in its category
- Best airflow range in its category
- Exclusive convertible HRV to an ERV (Latent Recovery Core)
- Gold Series blower design makes the unit quieter than ever

Superior Craftsmanship

- External electrical access side panel
- Integrated balancing dampers
- All parts removable in 5 minutes
- Aluminum framed foam filter
- Improved sliding system for core insertion
- Exclusive, deeper one piece condensation tray to prevent water leakage
- No sharp angles on metal parts
- Exclusive, reinforced cabinet
- Improved defrost damper and damper mechanism, designed to operate during the toughest weather conditions
- Frost Buster™: Defrost failure protection system designed to protect against damper malfunction

Tradition of Quality

- Proven technology and mechanical simplicity for heat recovery
- Low motor temperature operation for longer life expectancy
- 5-year warranty

Available at :

Controls and Options

- Built-in electronic circuit board ready to receive one of the following main controls:
 - Basic #40210
 - Electro #40220
- One of the following optional controls can be added:
 - Humidity Control #200694
 - 20-min. lighted push button #1806110
 - 60-min. mechanical timer #00910
 - 20/40/60-min. push button #03701
- Integrated furnace interlock relay
- Complete line of registers and diffusers available
- Electric duct heater
- On-line filters

No Negative Pressure Defrost

Defrost system ensures that no negative pressure is created by air exhausted to outside. Ambient air is recirculated into the house.

Outside temperature °C	Outside temperature (°F)	Defrost cycle Defrosting min./operating min.
-5 to -30	23 to -22	6/32
-30 & colder	-22 & colder	6/20

Heat Recovery Core

Dimensions: 12" x 12" x 16.75" (30.5 cm x 30.5 cm x 42.54 cm)

Exchange surface: 166 ft² (15.44 m²)

Weight: 9.5 lbs (4.3 kg)

Type: Crossflow

Material: Polypropylene

Warranty: Lifetime

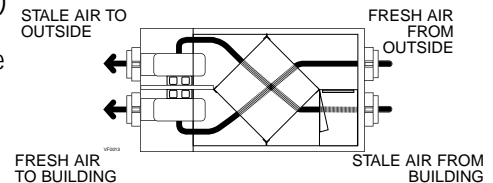

FROST BUSTER™: The Smart Defrost System

The Gold Series uses a defrost failure protection system that prevents the unit from allowing cold air to enter into the house. In the event of a damper motor relay or damper motor mechanism malfunction, the air entering the house from the core could be colder than -10°C (14°F). To avoid excessive cold air throughout the house or damage to the unit, the failure protection system will shut down the unit and the air exchange LED will flash to signal the failure. In case of minor problems, the system will command a second defrost sequence and a third if necessary before shutting down the unit when the temperature has not risen above +5°C (41°F).

Requirements and Standards

- Complies with the CSA C22.2 #113 Standard applicable to ventilators.
- Complies with the CSA C444 requirements regulating the installation of Energy Recovery Ventilators.
- Technical data was obtained from published results of tests relating to CSA C429 Standards.
- HVI certified.

Dimensions and Service Clearances of vanEE 2001 HRV

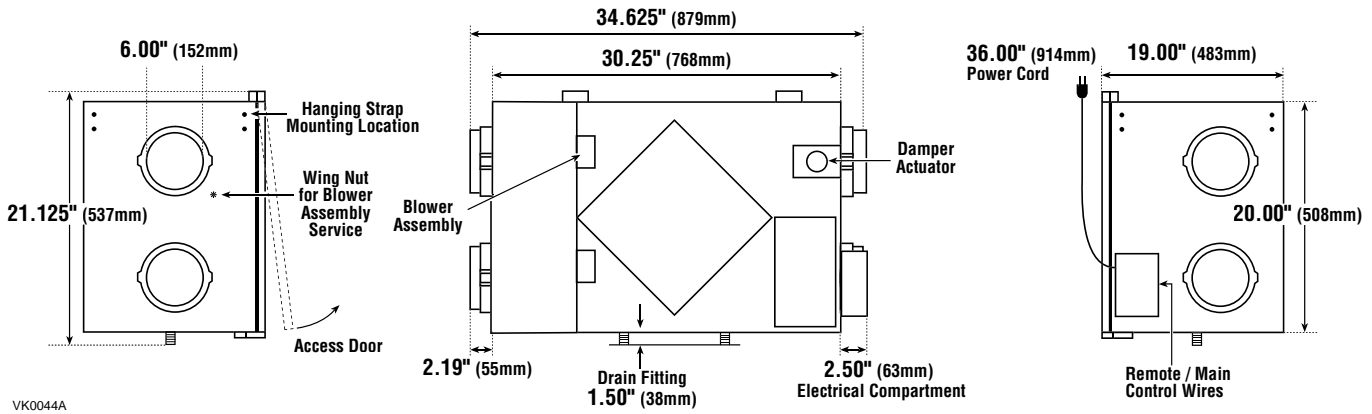

VK0044A

Ventilation Performance

External Static Pressure	Net Supply Air Flow	Gross Air Flow					
		Supply		Exhaust			
Pa	in. w.g.	l/s	cfm	l/s	cfm	l/s	cfm
50	0.2	120	253	124	264	126	268
75	0.3	118	250	123	262	119	251
100	0.4	111	235	116	245	114	241
125	0.5	102	216	106	224	107	226
150	0.6	87	185	91	193	96	204
175	0.7	75	160	78	167	81	172
200	0.8	57	120	59	124	57	121

Note: Unit operating at maximum speed.

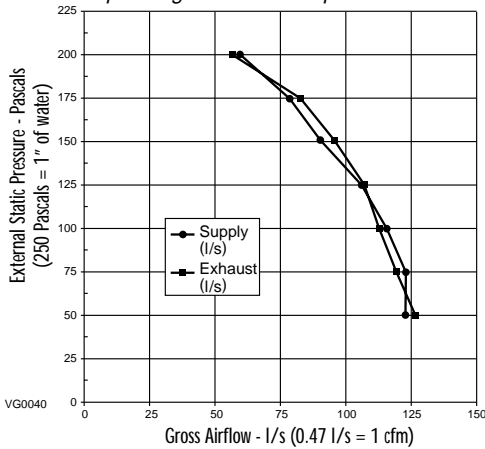

VG0040

Energy Performance

	Supply Temperature		Net Airflow		Average Sensible Power	Recovery Efficiency	Apparent Sensible Effectiveness	Latent Recovery Moisture Transfer
	°C	°F	l/s	cfm	Watts	%	%	
HEATING	0	32	51	109	92	70	77	-0.01
	0	32	73	155	128	65	72	-0.02
	0	32	102	215	191	62	70	-0.01
	-25	-13	52	110	104	60	94	0.05
Total recovery efficiency								
COOLING	35	95					Not tested	

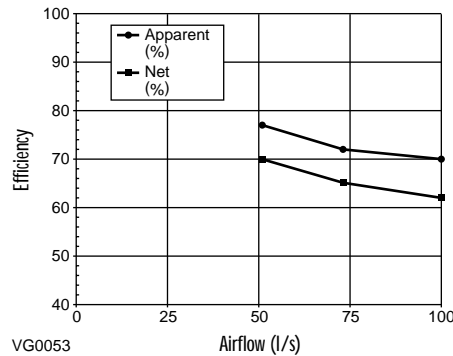

VG0053

Specifications and Ratings

- Model: vanEE 2001 HRV
- Part Number #45828
- Total Assembled Weight:
 - With polypropylene core: 73 lbs (33 Kg)
 - With enthalpic transfer media core: 73 lbs (33 Kg)
- Supply Air Duct Connections: 6" diameter
- Exhaust Air Duct Connections: 6" diameter
- Drains: 1/2" fittings
- Filters: 30 ppi washable reticulated foam
 - 11.75" x 16.75" x 0.75"
 - (29.85 x 42.55 x 1.9 cm)
- Cabinet: 20 ga. pre-painted steel
- Insulation: 1.00" aluminum foil faced fiberglass
- Mounting: Reinforced rubber straps (or chains) and hardware provided to suspend unit
- Supply & Exhaust Blower Motors:
 - Voltage: 120 volts
 - Hz: 60 Hz
 - HP: 1/7
 - RPM: 1630/1300/1040
 - Bearings: Sleeve bearings
- Type: PSC

- Fan Speed Control:
 - Low, increased low speed & high
 - Two speeds available to user.
 - Low or increased low speed is selected at the time of installation.

- Unit Electrical Characteristics:
 - Voltage: 120 volts
 - Power: 202 watts
 - Current: 1.9 amp



NOTE: All specifications are subjected to change without notice.

Submitted by:		Date:	Project:
Qty:	Model #:	Remarks:	Location:
			Architect:
			Engineer:
			Contractor:



550, Lemire Blvd., Drummondville, QC, Canada J2C 7W9 - Tel.: 1-800-567-3855 Fax: 1-800-567-1715



www.vanee-ventilation.com

01/04 PRODUCT SHEET #90197