

ERV 60H

Part #41606 (ports on top)

Part #41604 (ports on sides)

45 to 104 CFM (0.4 in. w.g.)



VB0073

AN INGENIOUS AIR EXCHANGE SOLUTION THAT'S AS VERSATILE AS IT IS COMPACT!

Configured with factory built vertical or horizontal ports, the Energy Recovery Ventilator 60H can fit almost anywhere. Hidden in a bulkhead or in a closet, it is the most versatile 100-cfm unit available on the market today. Among its exclusive features, this unit is equipped with integrated balancing and backdraft dampers in its exhaust to outside and fresh air supply ports. For a standard installation, there is no need to balance the unit*, thanks also to its twin high-pressure blowers. Its operation can be interlocked with an existing furnace without adding an extra relay. Also, for more convenience, its latches can be relocated on its front (as shown on unit picture). This compact, lightweight, and powerful unit is the ideal choice for small pre-fab and tract houses, condos, apartments and other limited space applications. What's more, it is the only air exchanger of its size that can be transformed from an ERV to an HRV, simply by changing its core.

*To avoid balancing, the difference between stale air ducts total length and fresh air ducts total length must not exceed 50 ft.

- 20% smaller than comparable 100-cfm units
- Versatile horizontal or vertical port configuration
- New removable terminal block to ease optional wall control connections
- Integrated pressure taps, if balancing required by building code
- State-of-the-art ventilation technology

REPAIRS AND MAINTENANCE

All parts of the vånEE ERV 60H that could need maintenance can be removed in less than five minutes, allowing direct access for easy repairs. The PSC motors are permanently lubricated. Finally, the removable electrical drawer with pull-out PCB assembly allows easy access for maintenance of major sub-components.

WARRANTY

The vånEE ERV 60H is protected by a 2-year warranty on parts only. The energy recovery core is covered by a 5-year warranty.

Available at:

ENERGY RECOVERY VENTILATOR

Controls

- This unit is very simple to operate: once it is installed, press on its push button, located on the bottom of the unit, to activate it. Press once for low speed, once again to high speed, and once more to stop it.
- For more convenience, the following main controls are available:
 - Lite-Touch Bronze #40270
 - Simple-Touch Bronze #40290
 - Bronze #40250
- Also, one to 5 of the following optional controls can be added:
 - 20-min. lighted push button #1806110
 - 60-min. mechanical timer #00910

Options

- Complete line of registers and diffusers
- Electric duct heater
- Dual exterior hood kit (including the Tandem® transition), part #14690

Homeshield™ Defrosting System

The vånEE ERV 60H uses a unique defrosting method. No negative pressure is created by air exhausted to the outside, as the air is recirculated into the house, thus avoiding any backdraft from the chimney.

	OUTSIDE TEMPERATURE		DEFROST CYCLE
	°C	(°F)	defrosting min. / operating min.
Warmer than -5	Warmer than (23)	No defrost	
-5 to -27	(23 to -17)	9/23	
-27 & LESS (-17 & LESS)		10/22	

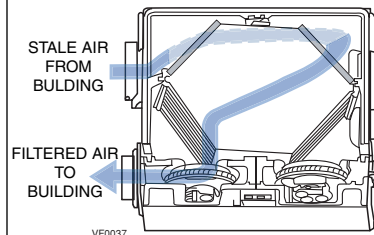

Energy Recovery Core

Dimensions: 19 1/8" x 13 7/16" x 6 7/8" (48.6 cm x 34.1 cm x 17.3 cm)

Exchange surface: 56 ft² (5.2 m²)

Weight: 9.25 lb (4.2 kg)

Material: Polymerized paper

Type: Crossflow and counterflow core

Warranty: 5 years

Requirements and Standards

- Complies with the UL 1812 requirements regulating the installation of Heat Recovery Ventilators
- Complies with the CSA C22.2 #113 Standard applicable to ventilators
- Complies with CSA C444 requirements regulating the installation of Energy Recovery Ventilators
- Technical data was obtained from published results of tests relating to CSA C439 Standards
- HVI certified

Dimensions and Service Clearances: v nEE ERV 60H (ports on sides)

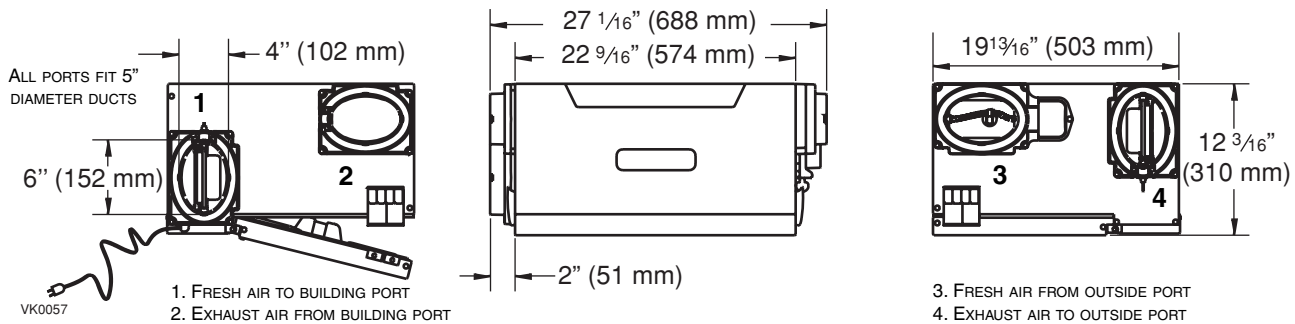

Ventilation Performance

EXT STATIC PRESSURE	NET SUPPLY AIR FLOW			GROSS AIR FLOW						
	Pa	in.w.g.	l/s	cfm	m ³ /h	SUPPLY			EXHAUST	
25	.1	55	116	197	56	119	202	59	125	212
50	.2	53	113	192	55	116	197	57	121	206
75	.3	50	107	182	52	111	189	54	115	195
100	.4	49	104	177	50	107	182	53	112	190
125	.5	46	98	166	48	101	172	50	105	178
150	.6	44	94	160	46	97	165	47	100	170
175	.7	42	88	150	43	91	155	45	95	161
200	.8	39	82	139	40	84	143	42	90	153

v nEE ERV 60H (ports on top)

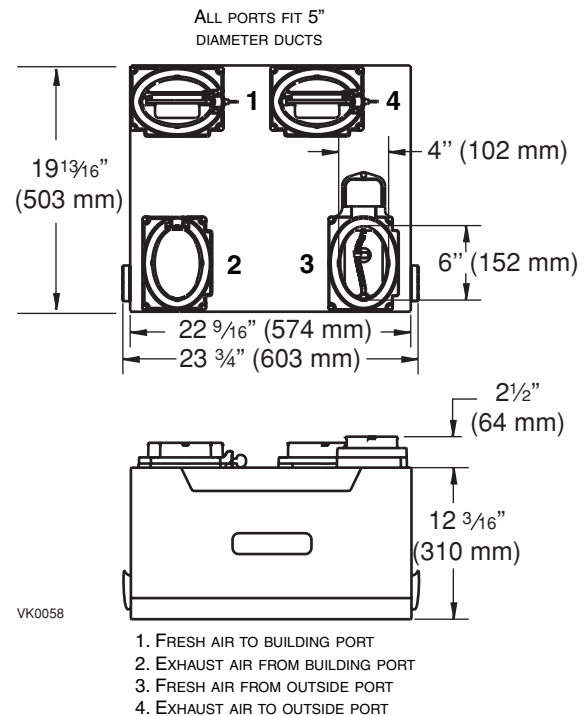

Energy Performance

SUPPLY TEMPERATURE		NET AIR FLOW			POWER CONSUMED	SENSIBLE RECOVERY EFFICIENCY	APPARENT SENSIBLE EFFECTIVENESS	MOISTURE RECOVERY TRANSFER
C	F	l/s	cfm	m ³ /h	WATTS			
HEATING								
0	+32	13	28	48	73	69	94	0.68
0	+32	45	96	163	137	62	74	0.48
-25	-13	25	54	92	102	54	83	0.58
COOLING								
+35	+95	14	29	49	70	TOTAL RECOVERY EFFICIENCY		54

NOTE: All specifications are subject to change without notice.

Specifications and Ratings

- Model: v nEE ERV 60H
- Part Number ports on top: #41606
- Part Number ports on sides #41604
- Total Assembled Weight: (Including polymerized paper core): 45 lb (20.4 kg)
- Oval shaped ports; fit 5" ducts
- Core filters: 30 ppi washable foam
- 8.75" x 6.75" x 0.5" (22.2 x 17.2 x 1.3 cm)

- Cabinet: 20 ga. pre-painted steel
- Insulation: expanded polystyrene
- Mounting: suspension by chains and springs
- Supply & Exhaust Blower Motors: 2 motors
- Protection type: Thermally protected
- Insulation class: B
- V (motor marking): 120 V ac, 60 Hz, 0.6 A, 3000 RPM

- Speed Control on unit: Low and High speed. Other modes available with main and optional wall controls
- Heat Recovery Core:
 - Exchange Surface Area: 56 ft² (5.2 m²)
 - Type: Crossflow and counterflow
 - Material: Polymerized paper
- Unit Electrical Characteristics:

Volts	Freq	Amperes	Watts
120	60 Hz	1.3	150

Submitted by:		Date:	Project:
Qty:	Model #:	Remarks:	Location:
			Architect:
			Engineer:
			Contractor:



Residential Product Group, 550 Lemire Blvd, Drummondville, QC, Canada J2C 7W9 - Tel.: 1-800-567-3855 Fax: 1-800-567-1715



www.vanee-ventilation.com

02/06 PRODUCT SHEET #91053