



User Guide

VIGÖR™ HRV PLUS AND VIGÖR™ ERV



VB0147

**Model no. 44202
(with top ports)**



VB0149

**Model no. 44212
(with top ports)**



VB0148

**Model no. 44203
(with side ports)**



VB0150

**Model no. 44213
(with side ports)**

PLEASE READ AND SAVE THESE INSTRUCTIONS.



7 72371 11399 2



These products earned the ENERGY STAR® by meeting strict energy efficiency guidelines set by Natural Resources Canada and the US EPA. They meet ENERGY STAR requirements only when used in Canada.

09176 rev. B

Congratulations!

You have made an excellent choice! The operating principle of your Heat or Energy Recovery Ventilator will give you personal comfort you have never known before.

We have prepared this User Guide especially for you. Please read it carefully to ensure you obtain full benefit from your unit. Over the coming months, you will increasingly appreciate the feeling of living in a more comfortable house.

Please take note that this manual uses the following symbols to emphasize particular information:

WARNING

Identifies an instruction which, if not followed, might cause serious personal injuries including possibility of death.

CAUTION

Denotes an instruction which, if not followed, may severely damage the unit and/or its components.

NOTE: Indicates supplementary information needed to fully complete an instruction.

We welcome any suggestions you may have concerning this guide and/or the unit, and we would appreciate hearing your comments on ways to better serve you. Please forward all correspondence to us at the address indicated on the product registration card included with this guide.

CAUTION

Make sure at all times that the outside intake and exhaust hoods are free from any snow during the winter season. It is important to check your unit during a big snow storm, so it doesn't draw in any snow. If this is the case, please operate the unit in the recirculation mode, or turn it OFF for a few hours.

Do not use your unit during construction or renovation of your house or when sanding drywall. This type of dust may damage your system.

Since the electronic control system of the unit uses a microprocessor, it may not operate correctly because of external noise or very short power failure. If this happens, unplug the unit and wait approximately 10 seconds. Then, plug the unit in again.

Table of Contents

1. DEFROSTING MODE	4
2. CONTROLS	4-13
2.1 <i>INTEGRATED CONTROL</i>	4-5
2.2 <i>PLATINUM PLAIN CONTROL</i>	6-9
2.3 <i>LITE-TOUCH CONSTRUCTO MAIN CONTROL</i>	10
2.4 <i>SIMPLE-TOUCH CONSTRUCTO MAIN CONTROL</i>	10
2.5 <i>CONSTRUCTO MAIN CONTROL</i>	11
2.6 <i>OPTIONAL AUXILIARY CONTROLS</i>	12-13
2.6.1 <i>20/40/60-minute Push-Button Timer</i>	12
2.6.2 <i>20-minute Lighted Push Button</i>	12
2.6.3 <i>Humidity Control</i>	13
2.6.4 <i>60-minute Crank Timer</i>	13
3. MAINTENANCE	14-15
3.1 <i>QUARTERLY MAINTENANCE</i>	14-15
3.2 <i>ANNUAL MAINTENANCE</i>	15
4. TROUBLESHOOTING	15-16

1. Defrosting Mode

When the outside temperature is below -5°C (23°F), recovery of heat or energy creates frost in the core.

To maintain its proper operation, the unit is programmed to defrost the recovery core. The defrost frequency varies according to the outside temperature.

During the defrost cycle, the unit shifts to maximum speed and the dampers close. After defrosting, the unit returns to the operating mode selected by the user.

2. Controls

2.1 Integrated Control

BOOTING SEQUENCE

The unit booting sequence is similar to a personal computer boot sequence. Each time the unit is plugged after being unplugged, or after a power failure, the unit will perform a 30-second booting sequence before starting to operate.

During the booting sequence, the integrated control LED will light GREEN for 5 seconds, and then will turn RED. During this RED light phase, the unit is checking and resetting the motorized damper position. Once the motorized damper position completely set, the RED light turns off and the booting sequence is done.

NOTE: No command will be taken until the unit is fully booted.

2. Controls (cont'd)

2.1 Integrated Control (cont'd)

All units are equipped with an integrated control, located on the upper left side of the unit.

Use the push button (1) to control the unit. The LED (2) will then show on which mode the unit is in.

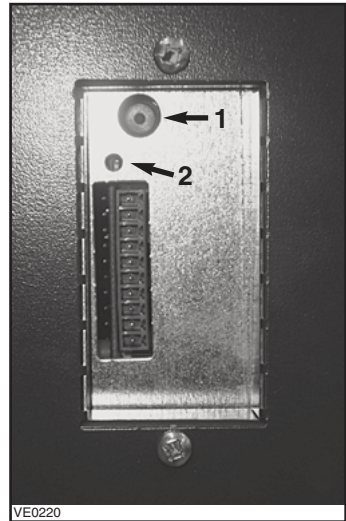

Refer to table below to see how to operate the unit using its integrated control.

PRESS ON PUSH BUTTON	LED COLOR	RESULTS
ONCE	AMBER	UNIT IS ON LOW SPEED
TWICE	GREEN	UNIT IS ON HIGH SPEED
THREE TIMES	NO LIGHT	UNIT IS OFF

If a problem occurs during the unit operation, its integrated control LED (2) will blink. The color of the blinking light depends on the type of error detected. Refer to Section 4 *Troubleshooting* on last page for further details.

NOTE: WHEN USING MAIN CONTROL, THE INTEGRATED CONTROL MUST BE TURNED OFF.

2. Controls (cont'd)

2.2 Platinum Main Control (cont'd)

CASING INDICATORS AND KEYS

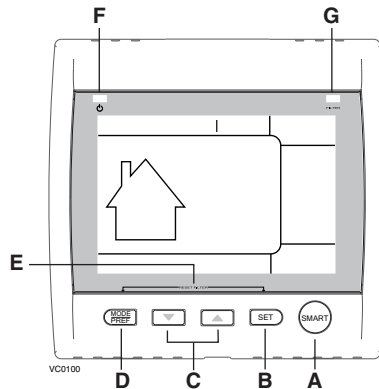

- A** SMART key: Enables and disables the **SMART** mode.
- B** Set key:
- Press 3 seconds to access setting periods for **Program mode**.
 - Confirms the chosen option and goes to following setting.
- C** Arrow keys:
- Adjust ventilation and recirculation speeds.
 - Allows to review the program's period.
 - Adjust **Preference** and **Program** values.
- D** Mode / Pref key:
- Mode: Selects whether **Ventilation**, **Recirculation** or **Program** mode.
 - Pref: Push 3 seconds to access **Preference** settings.
- E** Reset filter keys: Press on **B** and **D** keys simultaneously for 5 seconds to turn off (reset) the filter maintenance indicator.
- F** Power indicator: Illuminates when the control is operating.
- G** Filter maintenance indicator: When lit, shows it is time to perform filters maintenance. (Refer to Section 3 Maintenance).

2. Controls (cont'd)

2.2 Platinum Main Control (cont'd)

The Platinum main control is pre-programmed and ready to go. All you have to do is to set day and time. Then check the settings below and change if needed.

SETTING PREFERENCES

Press on **MODE / PREF** key (**D**) for 3 seconds.

NOTE: You can exit Preferences setting by pressing on **MODE / PREF** key (**D**) for 3 seconds any time in the process, or wait 60 seconds. The modified values will be kept in memory.

WHAT WILL YOU SEE

If the control will be set for the very first time, the current day will be the first setting to be made; **MON** (for Monday) will flash on screen.

If the control was previously set up, when setting preferences, the control returns to the last preference chosen on previous setting. While setting Preferences, the corresponding setting value flashes (e.g.: while setting current hour, hour is flashing).

HOW TO PROCEED

For every settings in table below:

- Use to select value.
- Press **SET** key (**B**) to confirm the selected preference and go to next setting.

SETTING	AVAILABLE VALUE	DEFAULT OPTIONS
CURRENT DAY	MON/TUE/WED/THU/FRI/SAT/SUN	MON
HOUR DISPLAY	12:00 ^{AM} OR 24:00	12:00 ^{AM}
CURRENT HOUR	FROM 0 TO 12 OR 24	12
CURRENT MINUTE	FROM 00 TO 59	00
TEMPERATURE UNIT	°C OR °F	°C
INSIDE TEMPERATURE DISPLAY	ON OR OFF	ON
MINIMUM OUTSIDE TEMPERATURE FOR AIR EXCHANGE*	-40°C TO 0°C OR -40°F TO 32°F	-25°C OR -13°F
MAXIMUM OUTSIDE TEMPERATURE FOR AIR EXCHANGE*	1°C TO 40°C OR 33°F TO 104°F	27°C OR 81°F
*IN PROG OR SMART MODE, THESE LIMIT VALUES ALLOW TO STOP AIR EXCHANGE WITH THE OUTSIDE.		
BACKLIGHT COLOR	BLUE OR GREEN	BLUE
BACKLIGHT DISPLAY	AUTO OR ON	AUTO
AUTO: BACKLIGHT ACTIVATED 10 SECONDS WHEN ANY KEY IS PRESSED. ON: BACKLIGHT ALWAYS ON.		
OFF MODE FOR INTERMITTENT MODE	VENTILATION/RECIRCULATION OR VENTILATION/OFF	VENT/RECIRC.
AFTER A VENTILATION PERIOD, DETERMINES THE SECOND PART OF THE CYCLE (RECIRCULATION OR OFF).		

2. Controls (cont'd)

2.2 Platinum Main Control (cont'd)

Pressing on **MODE / PREF** key (**D**) successively allows to go from **Ventilation** mode to **Recirculation** mode and then to **Program** mode (**VENT 5**, **RECIRC 4** and **PROG 3** on control screen).

- In **Ventilation** Mode, use to change the ventilation speed (displayed in **6** in all options except **RECIRC**).
- In **Recirculation** mode, use to change the recirculation speed (displayed in **6**, OFF, MAX).
- In **Program** mode, use to review the period settings without changing them (the period icons are displayed in **7**).

Pressing once on **A** allows to turn the ventilation unit in Smart mode. In this mode, the ventilation unit operation will be driven by the outdoor temperature and by the indoor conditions. Press once more to exit Smart mode.

SETTING PERIODS FOR PROGRAM MODE

The Program Mode allows the user to customize the operation of his/her ventilation unit, for week and weekend days. All days are divided in 4 periods. The periods starting hour and ventilation speed are factory set (see below).

DAILY PERIODS DEFAULT SETTINGS		
PERIOD	STARTING HOUR	MODE
PERIOD 1 (MORNING)	6:00 AM	MIN
PERIOD 2 (DAY)	9:00 AM	20 MIN/H
PERIOD 3 (EVENING)	5:00 PM	MIN
PERIOD 4 (NIGHT)	11:00 PM	20 MIN/H

To change these values:

Press on **SET** key (**B**) for 3 seconds, **PROG** (for program) will appear on screen, and week days will flash.

NOTE: You can exit Periods setting by pressing on **SET** key (**B**) for 3 seconds any time in the process, or wait 60 seconds.

- Use to select between setting week days or weekend days.
- Press **SET** key (**B**) to confirm the choice, and go to setting daily Period 1. (**Period 1** will appear on screen, and hour display will flash.)
- Use to select the period starting hour.
NOTE: Time changes by 15 minutes increments.
- Press **SET** key (**B**) to confirm and go to select the ventilation speed or type (will flash on screen).
- Use to select the ventilation speed or type.
- Press **SET** key (**B**) to confirm and go to daily Period 2. (**Period 2** will appear on screen, and hour display will flash.)
Proceed as for Period 1 for all daily periods. Once the ventilation speed or type for daily Period 4 has been selected:
- Press **SET** key (**B**) to confirm.

NOTE: If the week days were the first to be set, the weekend days will appear on screen; but if the weekend days were the first to be set, then the week days will appear on screen.

(**Period 1** will appear on screen, and hour display will flash).

- Set periods as described above.

2. Controls (cont'd)

2.3 Lite-Touch Bronze Main Control

Activate the push button; the color of the indicator shows the unit operating mode.

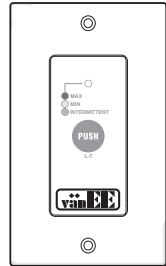

COLOR	MODE	SUGGESTED USE
GREEN	INTERMITTENT	SELECT THIS MODE WHEN YOU ARE AWAY FROM THE HOUSE FOR A FEW DAYS. ALSO, WHEN YOU DEEM THE INSIDE AIR IS TOO DRY IN HEATING SEASON, OR TOO HUMID DURING COOLING SEASON. IN THIS MODE, THE UNIT IS OFF FOR 40 MINUTES PER HOUR AND VENTILATES AT MINIMUM SPEED THE REMAINING 20 MINUTES OF THE HOUR.
YELLOW	MIN SPEED VENTILATION	FOR NORMAL DAILY OPERATION.
RED	MAX SPEED VENTILATION	FOR EXCESS POLLUTANTS AND HUMIDITY (PARTIES, ODORS, SMOKE, ETC.).

2.4 Simple-Touch Bronze Main Control

Activate the push button; the color of the indicator shows the unit operating mode.

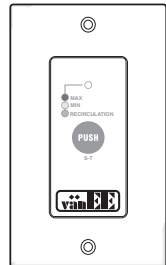

COLOR	MODE	SUGGESTED USE
GREEN	RECIRCULATION	SELECT THIS MODE WHEN YOU DEEM THE INSIDE AIR IS TOO DRY IN HEATING SEASON, OR TOO HUMID DURING COOLING SEASON. IN THIS MODE, THE UNIT STOPS EXCHANGING WITH THE OUTSIDE AND RECIRCULATES INSIDE AIR AT HIGH SPEED.
YELLOW	MIN SPEED VENTILATION	FOR NORMAL DAILY OPERATION.
RED	MAX SPEED VENTILATION	FOR EXCESS POLLUTANTS AND HUMIDITY (PARTIES, ODORS, SMOKE, ETC.).

2. Controls (cont'd)

2.5 Bronze Main Control

ADJUSTING AIR SUPPLY CONTROL

- 1) **Select** speed «MIN» or «MAX» using slide switch (A).
 - When «MIN» (minimum speed) is selected, if the knob (B) is set above the click, the unit will exchange in low speed with the outside and if it is set below the click, the unit will exchange on high speed with the outside until the desired humidity level has been reached.
 - When «MAX» (maximum speed) is selected, the unit will exchange on high speed with the outside either if the knob is set below or above the click.
- 2) To **turn off the unit**, slide the switch at the «OFF» position.

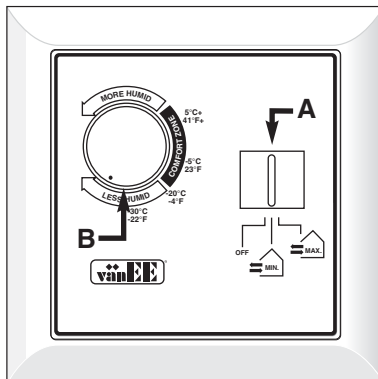

VC0039

ADJUSTING HUMIDITY CONTROL

Setting during the summer months:

During this period, unless being afflicted with breathing problems, using the Dehumidistat is unnecessary. Set the slide switch to «OFF». (Do not exchange in day time; exchange at night time, if cool outside, or if it is not raining.)

Setting during the fall, winter and spring months:

(When severe condensation appears on windows)

- 1) Determine the humidity level in your house (bring the knob (B) counterclockwise to its maximum position, then bring it back clockwise slowly until you hear a «click»).
- 2) Set the knob to one line under this temperature level or «click».

CAUTION

Do not select a temperature below -20°C (-4°F). This could lead to excessive dryness in the air causing discomfort for the occupants.

It is possible (and normal) to experience condensation on your windows when drastic changes in temperature happen (for example: -5°C [23°F] to -20°C [-4°F]). In that case, we suggest waiting a few days to allow the situation to stabilize.

2. Controls (cont'd)

2.6 Optional Auxiliary Controls

Contrary to the main controls, up to 5 optional auxiliary controls can be connected to the same ventilation unit.

2.6.1 20/40/60-minute Push-Button Timer

Location: Located in the bathroom or in other locations where there is temporary humidity excess or pollutants.

Purpose: To eliminate excess humidity produced by showers or other periodic activities producing pollutants.

Within 2 seconds, push one time for 20 minutes, two times for 40 minutes or three times for a 60-minute activation.

Results expected:

1. Motor speed: high for 20, 40 or 60 minutes.
2. Indicator light goes "ON" and flashes every 5 seconds (one time to indicate a 20-minute operation, two times for a 40-minute, and three times for a 60-minute operation).
3. Air exchange indicator light goes "ON".

NOTE: To stop activation, push one more time.

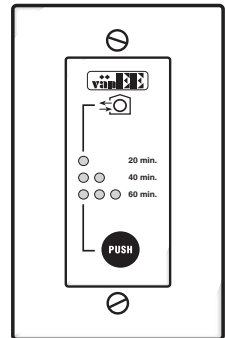

VC0041

2.6.2 20-minute Lighted Push Button

Press once to activate the push button. The unit will exchange air with the outside on high speed for 20 minutes and the indicator will light up. To stop activation before the end of the 20-minute cycle, push one more time. The unit will get back to its previous setting.

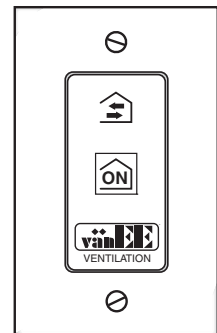

VC0040

3. Maintenance

⚠ WARNING

Risk of electric shock. Before performing any maintenance or servicing, always disconnect the unit from its power source. Sharp edges may be present. When cleaning the unit, it is recommended to wear safety glasses and gloves.

Refer to picture beside to identify the inner parts of your unit.

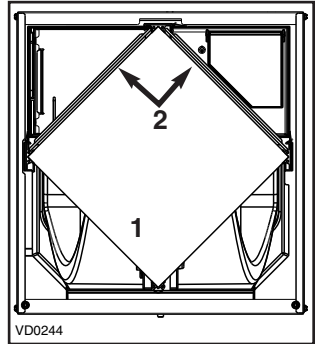

VD0244

1) Core

2) Core filters

3.1 Quarterly Maintenance

1. Unplug the unit.

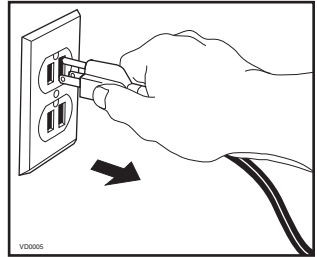

VD0005

2. Remove the unit door by following these steps:
 - A. Remove both door lower machine screws no. 8-32 x 1" (1) and set aside.
 - B. Open (2) and lift out the door (3).

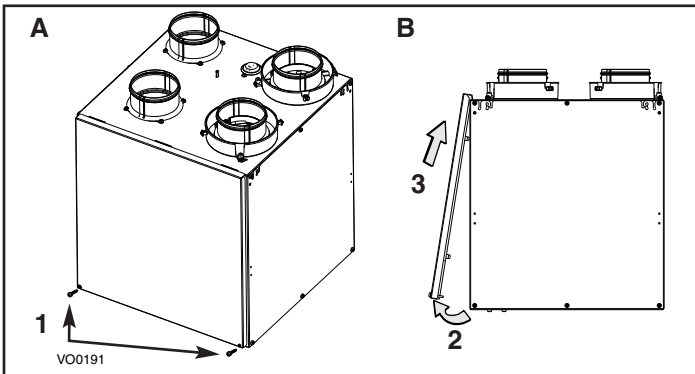

VO0191

3. Maintenance (cont'd)

3.1 Quarterly Maintenance (cont'd)

3. Slide out both filters (1) and recovery core (2) from the unit.
4. Clean the inside walls of the unit with a clean damp cloth, then wipe with a clean dry one.
5. Remove dust on filters and on core using a vacuum cleaner and a soft brush attachment.
6. Wash both core filters under lukewarm water with mild soap. Rinse thoroughly and let dry completely before reinstalling on the core.

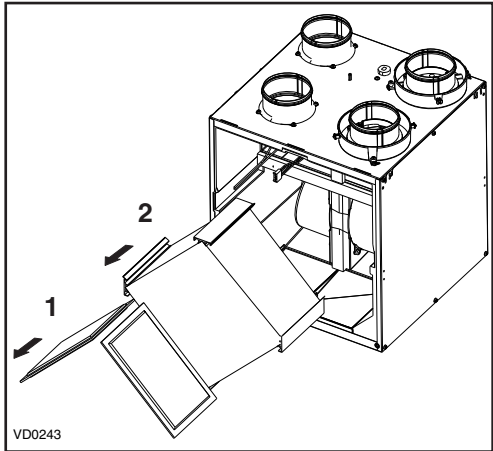

CAUTION

Follow the instructions on the core label to reinstall it correctly.

7. Slide the core and the cleaned filters into the unit.
8. Reinstall the door. Secure it with both mechanical screws no. 8-32 x 1" previously removed and plug the unit.

NOTE: The unit will return to its previous setting after a 30-second delay for boot sequence.

3.2 Annual Maintenance

Do the same operations as the Quarterly Maintenance (Section 3.1), and clean the recovery core as follows (refer to the core label):

HRV units: Soak the heat recovery core in a mixture of lukewarm water and mild soap. Rinse thoroughly. Shake the core to remove excess water and let it dry.

ERV units: Remove the dust on the core using a vacuum cleaner and a soft brush attachment.

After reinstalling the core and filters the unit's door, then clean the exterior hoods.

4. Troubleshooting

PROBLEMS		TRY THIS...
1.	On Platinum wall control, there is no outside temperature displayed on screen .	<ul style="list-style-type: none"> • At its very start-up or after a power failure, it Takes some minutes before the outside temperature appears on screen. Set the wall control on MIN or MAX in VENT Mode. • If the problem is not solved by the above, contact your installer.
2.	On Platinum wall control, error code E1, E3 or E4 appears on screen.	<ul style="list-style-type: none"> • Contact your installer.

4. Troubleshooting (cont'd)

PROBLEMS		TRY THIS...
3.	Nothing works.	<ul style="list-style-type: none"> • See if the unit is plugged in. • See if the unit is receiving power from the house circuit breaker or fuse.
4.	Condensation on windows. (Air too humid.)	<ul style="list-style-type: none"> • See <i>Controls</i> Section on pages 4 to 13. • Leave curtains half-open to allow air circulation. • Store all firewood in a close room with a dehumidifier or in a well ventilated room, or store the wood outside. • Do not adjust the thermostat of your heating system below 18°C (64°F).
5.	Inside air too dry.	<ul style="list-style-type: none"> • Temporarily use a humidifier. • See <i>Controls</i> Section on pages 4 to 13.
6.	Air too cold at the air supply grille.	<ul style="list-style-type: none"> • Check if the exterior hood is not blocked. • See <i>Controls</i> Section on pages 4 to 13. • Install a duct heater.
7.	The LED of the integrated control is blinking green.	<ul style="list-style-type: none"> • There is a problem with the thermistor. The unit is still working, but will defrost frequently. Contact your installer.
8.	The LED of the integrated control is blinking amber.	<ul style="list-style-type: none"> • There is a problem with the motorized damper. The unit is OFF. For a 2½-hour period, the unit will try to reset the damper at every 30 minutes. After 2½ hours, if the problem is not solved, the unit stops trying to reset damper. • Contact your installer.
9.	The integrated control push button does not work.	<ul style="list-style-type: none"> • The 30-second boot sequence is not completed. • See <i>Integrated Control</i> on page 4.

REPLACEMENT PARTS AND REPAIR

In order to ensure your ventilation unit remains in good working condition, you must use vänEE genuine replacement parts only. vänEE genuine replacement parts are specially designed for each unit and are manufactured to comply with all the applicable certification standards and maintain a high standard of safety. Any third party replacement part used may cause serious damage and drastically reduce the performance level of your unit, which will result in premature failing. vänEE also recommends to contact a vänEE certified service depot for all replacement parts and repair.

If the problem is still not solved, call your installer or the nearest approved Service Center. Also, you can reach the Customer Service Department at the following phone number: 1-800-567-3855.