

---

# User Manual

---

**READ AND SAVE THESE INSTRUCTIONS**



VB0140

---

**vänEE**

---

**2000 HE**

---

**3000 HE**

---

---

**VENMAR**

---

**1.8 HE**

---

**2.6 HE**

---



These products earned the ENERGY STAR® by meeting strict energy efficiency guidelines set by Natural Resources Canada and the US EPA. They meet ENERGY STAR requirements only when used in Canada.



7 72371 05969 6

VVI, 550 Lemire Blvd., Drummondville, QC, Canada  
J2C 7W9

02053 rev. C

## Congratulations!

You have made an excellent choice!

The operating principle of your Heat Recovery Ventilator will protect your house and give you personal comfort you have never known before.

We have prepared this User Manual especially for you. Please read it carefully to ensure you obtain full benefit from your Heat Recovery Ventilator unit. Over the coming months, you will increasingly appreciate the feeling of living in a more comfortable house.

Please take note this manual uses the following symbols to emphasize particular information:

### **WARNING**

**Identifies an instruction which, if not followed, might cause serious personal injuries including possibility of death.**

### **CAUTION**

**Denotes an instruction which, if not followed, may severely damage the unit and/or its components.**

NOTE: Indicates supplementary information needed to fully complete an instruction.

We welcome any suggestions you may have concerning this manual and/or the unit, and we would appreciate hearing your comments on ways to better serve you. Please forward all correspondence to us at the address indicated on the product registration card included with this manual.

### **CAUTION**

**Make sure at all times that the outside hoods are free from any snow during the winter season. It is important to check your unit during a big snow storm, so it doesn't draw any snow. If this is the case, please operate the unit in recirculation mode, or OFF mode, for a few hours.**

**Do not use your HRV during construction or renovation of your house or when sanding drywall. This type of dust may damage your system.**

**Since the electronic control system of the unit has a microprocessor incorporated, it may not operate correctly because of the external noise or very short power failure. If this happens, unplug the unit and wait approximately 10 seconds. Then, plug the unit in again.**

---

---

# TABLE OF CONTENTS

---

---

<b>1. FUNCTIONS OF YOUR HRV .....</b>	<b>4</b>
1.1 <i>Air Exchange</i> .....	4
1.2 <i>Heat Recovery</i> .....	4
1.3 <i>Recirculation</i> .....	4
<b>2. DIAGRAMS OF AIRFLOWS .....</b>	<b>5</b>
<b>3. DESCRIPTION OF THE UNIT .....</b>	<b>6-7</b>
<b>4. OPERATING THE WALL CONTROL.....</b>	<b>8-14</b>
4.1 <i>Basic and Venta Main Controls</i> .....	9
4.2 <i>Altitude and Platinum Main Controls</i> .....	10-13
4.3 <i>Using the Optional Controls</i> .....	14
<b>5. MAINTENANCE .....</b>	<b>15</b>
5.1 <i>Regular Maintenance</i> .....	15
5.2 <i>Annual Maintenance</i> .....	15
<b>6. TROUBLESHOOTING .....</b>	<b>16</b>

# 1. FUNCTIONS OF YOUR HRV

Your Heat Recovery Ventilator eliminates the excessive humidity problems by exhausting stale and humid air to the outside and by drawing in fresh air. The unit offers superior air quality and fresh air sensation, an important factor to overall comfort, by eliminating the accumulation of pollutants and humidity.

The unit also comes equipped with a heat recovery core which reduces ventilating costs in winter.

The Heat Recovery Ventilator is a ventilation system which carries out three main operations:

## 1.1 AIR EXCHANGE

The unit exhausts stale and humid air from the house and replaces it with fresh air from the outside.

MODELS	RATES
2000 HE / HE 1.8	55 to 93 l/s (115 to 197 cfm)
3000 HE / HE 2.6	85 to 141 l/s (180 to 300 cfm)

## 1.2 HEAT RECOVERY

During winter, the unit recovers the heat contained in the stale air before it is exhausted, and transfers it to the fresh air drawn from the outside (reverse process in summer).

**Example (in winter):**

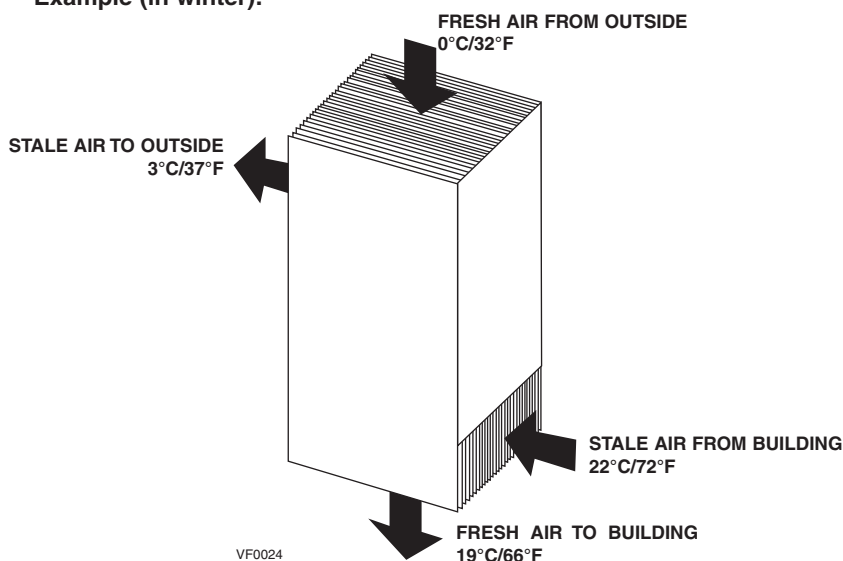

## 1.3 RECIRCULATION (AVAILABLE WITH ALTITUDE OR PLATINUM CONTROLS ONLY)

During the recirculation mode, the units stops to exchange air with the exterior. Continuous recirculation is thus undertaken inside the home and insures the purification of the ambient air. Two mechanical filters trap the large dust particles (those visible to the eye).

## 2. DIAGRAMS OF AIRFLOWS

### During air exchange

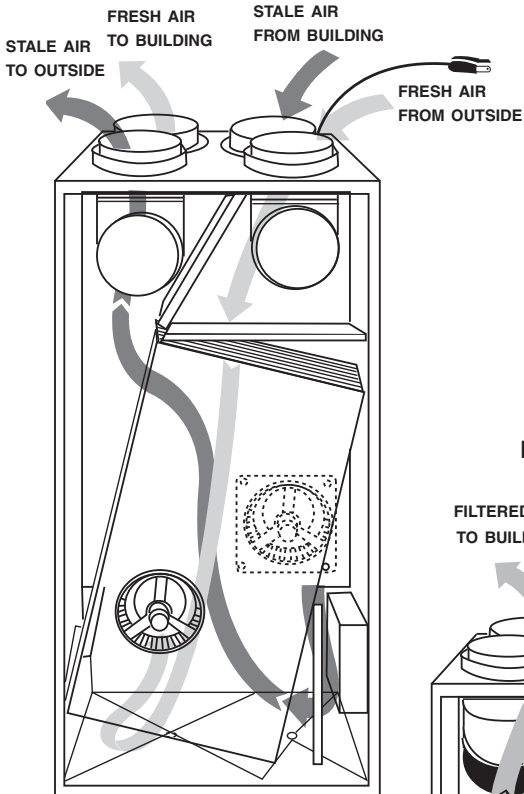

VF0025

### During recirculation and defrost mode

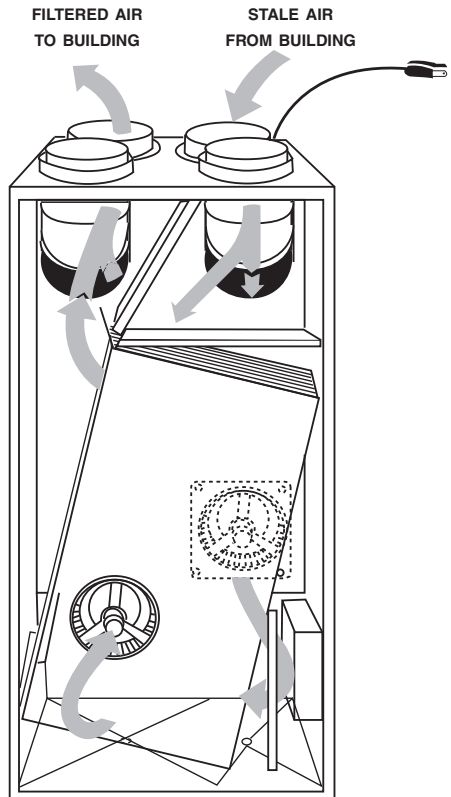

VF0002

---

### 3. DESCRIPTION OF THE UNIT

---

- 1 Stale air intake port:** is connected to the registers located in the larger rooms of the house.
- 2 Fresh air port:** brings fresh air from the outside into the unit.
- 3 Exhaust port:** exhausts stale air to the outside, after the air has transferred its heat inside the heat recovery core.
- 4 Distribution port:** distributes fresh air into the house, after it has absorbed the heat of the stale air in the heat recovery core.
- 5 Mechanical Filters:** trap the dust contained in the air and prevent the heat recovery core from becoming obstructed.
- 6 Heat recovery core:** is a counterflow type. It transfers the heat between the two air streams.
- 7 Blowers:** draw fresh air from the outside and exhaust stale air to the outside. The blower wheels are driven by two motors.
- 8 Capacitor:** is indispensable to proper motor operation.
- 9 Condensation tray:** is used to capture the water produced during heat transfer and defrost (in cold climate).
- 10 Drainage tube:** is connected to the condensation tray and serves to drain the water within.
- 11 Electronic control circuit:** located inside the electrical box, insures proper operation of the unit.
- 12 Automatic defrost unit:** consists of one damper actuator, dampers and related controls. The defrost cycle is electronically controlled in response to the outside temperature (-5°C [23°F] to -40°C [-40°F]) and will increase in frequency as the temperature decreases. Its duration is of 5 or 6 minutes according to models.
- 13 Control connector:** located inside the electrical box, allows to connect the control and override switch as a timer, a dehumidistat or a switch.
- 14 Electrical cord:** for 120 V electrical supply.

### 3. DESCRIPTION OF THE UNIT (CONT'D)

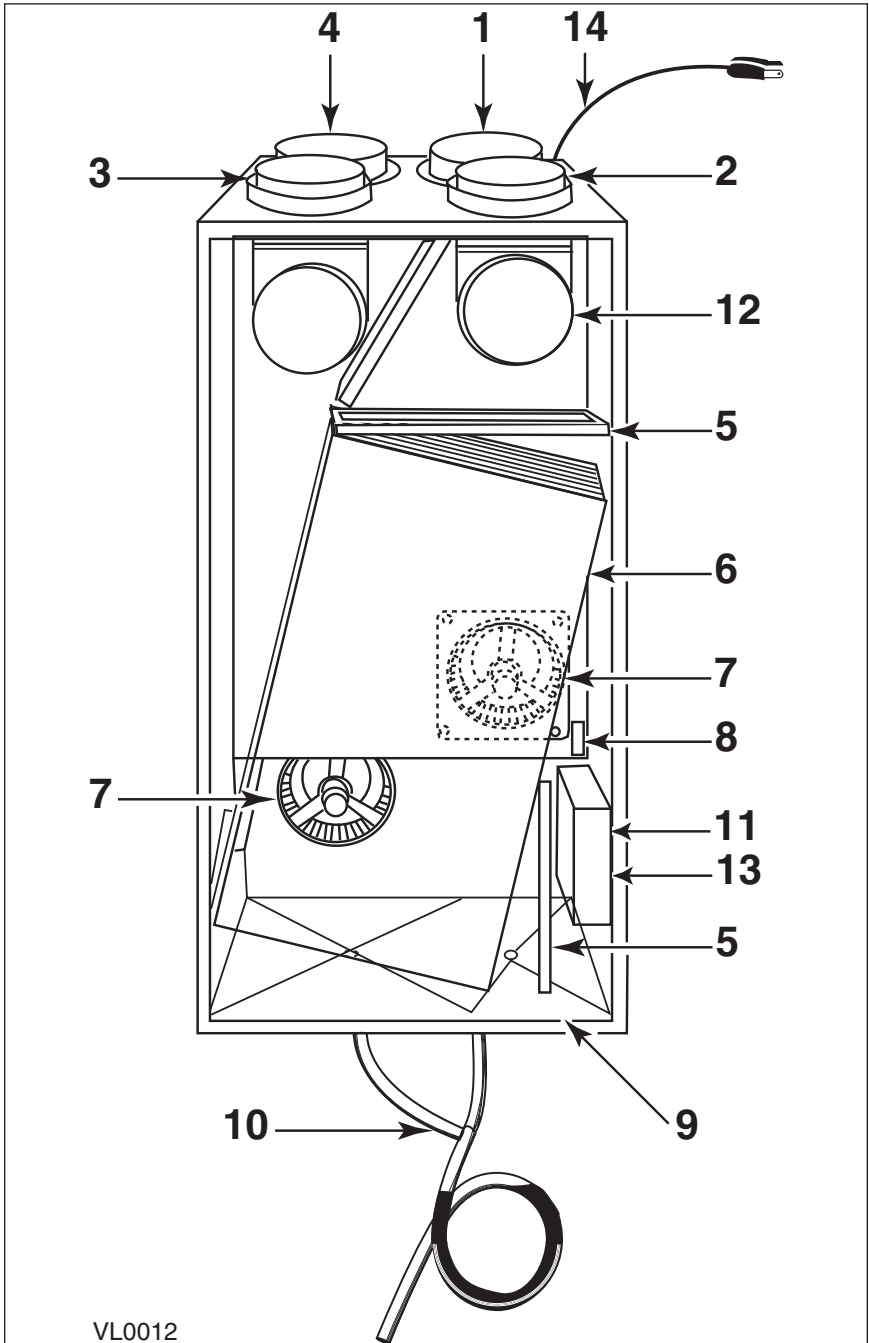

VL0012

## 4. OPERATING THE WALL CONTROLS

The following illustrations show the main controls. Refer to next pages for operating instructions.

**2000 HE**  
**3000 HE**

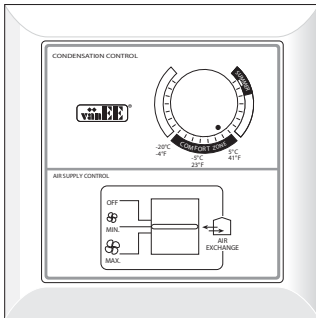

VC0035

**BASIC**

**HE 1.8**  
**HE 2.6**

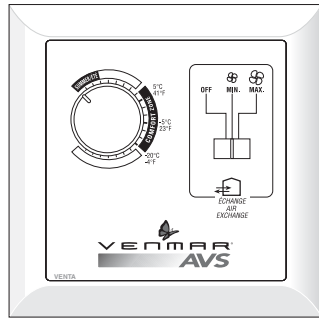

VC0010

**VENTA**

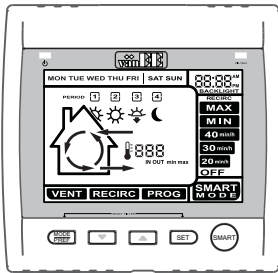

VC0104

**PLATINUM**

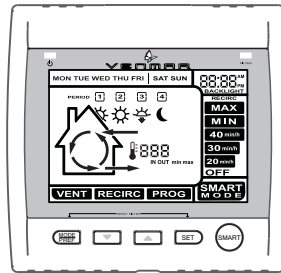

VC0101

**ALTITUDE**

---

## 4. OPERATING THE WALL CONTROLS (CONT'D)

---

### 4.1 BASIC AND VENTA MAIN CONTROLS

---

**Purpose:** To adjust air supply and select desired indoor humidity level.

#### ADJUSTING THE AIR SUPPLY CONTROL

- a) **Select** speed “MIN.” or “MAX.” using slide switch.
- When “MIN.” (minimum speed) is selected, if the knob is set above the click, the unit will exchange in low speed with the outside and if it is set below the click, the unit will exchange on high speed with the outside until the desired humidity level has been reached.
  - When “MAX.” (maximum speed) is selected, the unit will exchange on high speed with the outside either if the knob is set below or above the click.
- b) To **turn the unit off**, slide the switch at the “OFF” position.

#### ADJUSTING THE HUMIDITY CONTROL

##### **Setting during the summer months:**

During this period, unless being afflicted with breathing problems, using the humidity control is unnecessary. Set the slide switch to “OFF”. (Do not exchange in day time; exchange at night time, if cool outside, or if it is not raining).

##### **Setting during the fall, winter and spring months:**

**(When condensation appears on windows)**

- 1) Determine the humidity level in your house (bring the knob counterclockwise to its maximum position, then bring it back clockwise slowly until you hear a “click”).

#### **CAUTION**

**Do not set a temperature below -20°C (-4°F). This could lead to excessive dryness in the air causing discomfort for the occupants.**

- 2) Set knob to one line under this temperature level or “click”.

**It is possible (and normal) to experience condensation on your windows when drastic changes in temperature happen (for example: -5°C [23°F] to -20°C [-4°F] within few hours). In that case, we suggest waiting a few days to allow the situation to stabilize.**

## 4. OPERATING THE WALL CONTROLS (CONT'D)

### 4.2 ALTITUDE AND PLATINUM MAIN CONTROLS

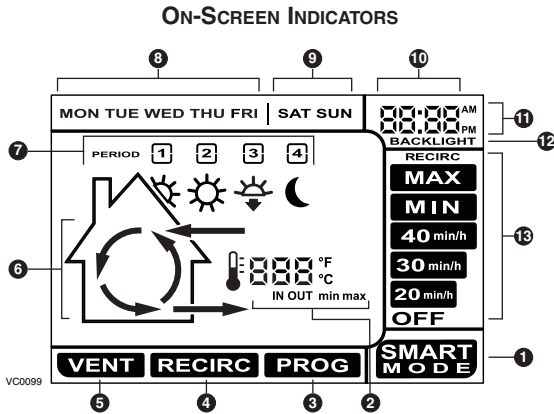

- 1 **SMART Mode.** Entirely automatic mode optimizing the ventilation.
- 2 **Temperature Indicators.**
- 3 **Program Mode.** Allows to program the desired ventilation according to the period of the day.
- 4 **Recirculation Mode.** Manual mode performing air recirculation inside the house.
- 5 **Ventilation Mode.** Manual mode performing air exchange with the outside.
- 6 Animated arrows showing ventilation status (recirculation or air exchange).
- 7 Periods of the day (morning, day, evening and night).
- 8 Week days.
- 9 Week-end days.
- 10 Hour display.
- 11 AM or PM display.
- 12 Appears only when setting backlight preferences.
- 13 Ventilation / Recirculation speeds and programming options.

---

## 4. OPERATING THE WALL CONTROLS (CONT'D)

---

### 4.2 ALTITUDE AND PLATINUM MAIN CONTROLS (CONT'D)

---

#### CASING INDICATORS AND KEYS

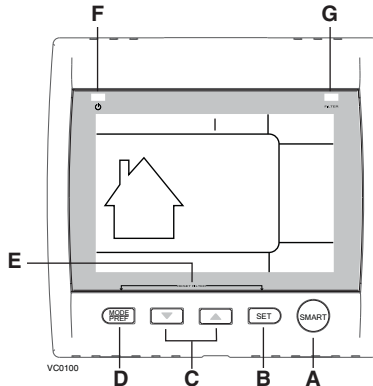

- A SMART key:** Enables and disables the **SMART** mode.
- B Set key:**
- Press 3 seconds to access setting periods for Program mode.
  - Confirms the chosen option and goes to following setting.
- C Arrow keys:**
- Adjust ventilation and recirculation speeds.
  - Allows to review the program's period.
  - Adjust Preference and Program values.
- D Mode/Pref key:**
- Mode: Selects whether **Ventilation**, **Recirculation** or **Program** mode.
  - Pref: Push 3 seconds to access Preference settings.
- E Reset filter keys:** Press on **B** and **D** keys simultaneously for 5 seconds to turn off (reset) the filter maintenance indicator.
- F Power indicator:** Illuminates when the control is operating.
- G Filter maintenance indicator:** Perform filters maintenance (Refer to Section 5 Maintenance).

## 4. OPERATING THE WALL CONTROLS (CONT'D)

### 4.2 ALTITUDE AND PLATINUM MAIN CONTROLS (CONT'D)

Both Altitude and Platinum main controls are pre-programmed and ready to go. All you have to do is to set day and time. Then check the settings below and change if needed.

#### SETTING PREFERENCES

Press on **MODE/PREF** key (D) for 3 seconds.

NOTE: You can exit Preferences setting by pressing on **MODE/PREF** key (D) for 3 seconds any time in the process, or wait 60 seconds. The modified values will be kept in memory.

#### WHAT WILL YOU SEE

If the control will be set for the very first time, the current day will be the first setting to be made; **MON** (for Monday) will flash on screen.

If the control was previously set up, when setting preferences, the control returns to the last preference chosen on previous setting. While setting Preferences, the corresponding setting value flashes (i.e.: while setting current hour, hour is flashing).

#### HOW TO PROCEED

For every settings in table below:

- Use   to select value.
- Press **SET** key (B) to confirm the selected preference and go to next setting.

SETTING	AVAILABLE VALUE	DEFAULT OPTIONS
CURRENT DAY	MON/TUE/WED/THU/FRI/SAT/SUN	MON
HOUR DISPLAY	12:00 <sup>AM</sup> OR 24:00	12:00 <sup>AM</sup>
CURRENT HOUR	FROM 0 TO 12 OR 24	12
CURRENT MINUTE	FROM 00 TO 59	00
TEMPERATURE UNIT	°C OR °F	°C
INSIDE TEMPERATURE DISPLAY	ON OR OFF	ON
MINIMUM OUTSIDE TEMPERATURE FOR AIR EXCHANGE*	-40°C TO 0°C OR -40°F TO 32°F	-25°C OR -13°F
MAXIMUM OUTSIDE TEMPERATURE FOR AIR EXCHANGE*	1°C TO 40°C OR 33°F TO 104°F	27°C OR 81°F
*IN PROG OR SMART MODE, THESE LIMIT VALUES ALLOW TO STOP AIR EXCHANGE WITH THE OUTSIDE.		
BACKLIGHT COLOR	BLUE OR GREEN	BLUE
BACKLIGHT DISPLAY	AUTO OR ON	AUTO
AUTO: BACKLIGHT ACTIVATED 10 SECONDS WHEN ANY KEY IS PRESSED. ON: BACKLIGHT ALWAYS ON.		
OFF MODE FOR INTERMITTENT MODE	VENTILATION/RECIRCULATION OR VENTILATION/OFF	VENT/RECIRC.
AFTER A VENTILATION PERIOD, DETERMINES THE SECOND PART OF THE CYCLE (RECIRCULATION OR OFF).		

## 4. OPERATING THE WALL CONTROLS (CONT'D)

### 4.2 ALTITUDE AND PLATINUM MAIN CONTROLS (CONT'D)

Pressing on **MODE/PREF** key (D) successively allows to go from **Ventilation** mode to **Recirculation** mode and then to **Program** mode (**VENT** 5, **RECIRC** 4 and **PROG** 3 on control screen).

- In **Ventilation** Mode, use   to change the ventilation speed (displayed in ⑬ except **RECIRC**).
- In **Recirculation** mode, use   to change the recirculation speed (displayed in ⑬, OFF, MIN, MAX).
- In **Program** mode, use   to review the period settings without changing them (the period icons are displayed in ⑦).

Pressing once on **A** allows to turn the ventilation unit in Smart mode. On this mode, the ventilation unit operation will be driven by the outdoor temperature and by the indoor conditions. Press once more to exit Smart mode.

#### SETTING PERIODS FOR PROGRAM MODE

The Program Mode allows the user to customize the operation of his/her ventilation unit, for week and weekend days. All days are divided in 4 periods. The periods starting hour and ventilation speed are factory set (see below).

DAILY PERIODS DEFAULT SETTINGS		
PERIOD	STARTING HOUR	MODE
PERIOD 1 (MORNING)	6:00 AM	MIN
PERIOD 2 (DAY)	9:00 AM	20 MIN/H
PERIOD 3 (EVENING)	5:00 PM	MIN
PERIOD 4 (NIGHT)	11:00 PM	20 MIN/H

#### To change these values:

Press on **SET** key (B) for 3 seconds, **PROG** (for program) will appear on screen, and week days will flash.

NOTE: You can exit Periods setting by pressing on **SET** key (B) for 3 seconds any time in the process, or wait 60 seconds.

- Use   to select between setting week days or weekend days.
- Press **SET** key (B) to confirm the choice, and go to setting daily Period 1. (**Period 1** will appear on screen, and hour display will flash.)
- Use   to select the period starting hour.  
NOTE: Time changes by 15 minutes increments.
- Press **SET** key (B) to confirm and go to select the ventilation speed or type (will flash on screen).
- Use   to select the ventilation speed or type.
- Press **SET** key (B) to confirm and go to daily Period 2. (**Period 2** will appear on screen, and hour display will flash.)

Proceed as for Period 1 for all daily periods. Once the ventilation speed or type for daily Period 4 has been selected:

- Press **SET** key (B) to confirm.

NOTE : If the week days were the first to be set, the weekend days will appear on screen; but if the weekend days were the first to be set, then the week days will appear on screen.

(**Period 1** will appear on screen, and hour display will flash.)

- Set periods as described above.

## 4. OPERATING THE WALL CONTROLS (CONT'D)

### 4.3 USING THE OPTIONAL CONTROLS

**Location:** Located in the bathroom or in other locations where there is temporary excess humidity or pollutants.

**Purpose:** To eliminate excess humidity produced by showers or other periodic activities producing pollutants.

#### **20/40/60-MINUTE PUSH-BUTTON TIMER:**

Activate the push button. Within 2 seconds, push once for 20 minutes, twice for 40 minutes or three times for a 60-minute activation.

#### **Results expected:**

1. Motor speed: High for 20, 40 or 60 minutes.
2. Indicator light goes "ON" and flashes every 5 seconds (one time to indicate a 20-minute operation, two times for a 40-minute, and three times for a 60-minute operation).

NOTE: To stop activation, push one more time.

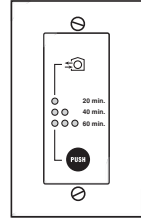

VC0046

#### **60-MINUTE CRANK TIMER:**

Activate the timer.

#### **Results expected:**

1. Motor speed: High for either 20, 40 or 60 minutes.
2. Indicator light goes "ON".

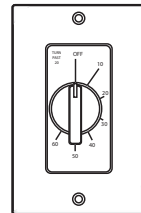

VC0017

High speed activation time	Position of dial
20 minutes	1 to 19
40 minutes	20 to 39
60 minutes	40 to 60

---

## 5. MAINTENANCE

---

### WARNING

**Dangerous voltage may be present. During maintenance and repairs, the unit must always be turned off, then unplugged. We take great care to minimize sharp edges; however, please proceed with caution when handling all components. When cleaning the unit, it is recommended to wear safety glasses and gloves.**

### 5.1 REGULAR MAINTENANCE

---

1. The motors are factory lubricated for life. Lubricating the bearings is not recommended.

### CAUTION

**Because the unit is suspended, two people are recommended to remove or install the heat recovery core.  
Do not hold the heat recovery core using its plastic extrusions as handles.**

2. The heat recovery core must be handled with care. We recommend that it be washed once a year, following the season of most intense use, in order to insure maximum efficiency of the plastic partitions.  
Allow the heat recovery core to soak for 3 hours in a solution of warm water and mild soap. Rinse under a heavy stream of water.

### CAUTION

**Hot water and a strong detergent will damage the heat recovery core.**

3. The air filters are washable. Under normal conditions, we recommend that they be washed every 3 months.  
Use vacuum cleaner to remove the heaviest portion of accumulated dust, then wash in hot water.
4. Regularly check the screen on the exterior intake hood and clean when necessary. Also check during very cold weather because ice may grow on the screen located at the exterior intake hood.

### 5.2 ANNUAL MAINTENANCE

---

NOTE: Ask your installer for an annual service contract.

Annual service should include:

- 1) Cleaning filters, heat recovery core and the exterior air intake/exhaust hood.
- 2) Cleaning the wheels and the blower blades.
- 3) Cleaning the condensation tray with soapy water (make sure that the drain is not clogged).
- 4) Running the system and checking the different operating modes.
- 5) Measuring and calibrating (if need be) rates of flow.

## 6. TROUBLESHOOTING

If you think your unit is malfunctioning, check some of the following:

	TYPE OF PROBLEM	TRY THIS...
1.	On Altitude or Platinum wall control, there is no outside temperature displayed on screen 	<ul style="list-style-type: none"> <li>At its very start-up or after a power failure, it takes some minutes before the outside temperature appears on screen. Set the wall control on MIN or MAX in VENT Mode.</li> <li>If the problem is not solved by the above, contact your installer.</li> </ul>
2.	On Altitude or Platinum wall control, error code E1, E3 or E4 appears on screen.	<ul style="list-style-type: none"> <li>Contact your installer.</li> </ul>
3.	Nothing works.	<ul style="list-style-type: none"> <li>See if the unit is plugged in.</li> <li>See if the unit is receiving power from the house circuit breaker or fuse.</li> </ul>
4.	Condensation on windows. (Air too humid.)	<ul style="list-style-type: none"> <li>Adjust the humidity control knob as per instructions (see Section 4).</li> <li>Operate the unit at maximum speed (MAX.) during activities generating excess humidity (family gatherings, extra cooking, etc.).</li> <li>Leave curtains half-open to allow air circulation.</li> <li>Store all firewood in a close room with a dehumidifier or in a well ventilated room, or store the wood outside.</li> <li>Keep the temperature in your house above 18°C (64°F).</li> </ul>
5.	Air too dry.	<ul style="list-style-type: none"> <li>Do not adjust your humidity control below -20°C (-4°F).</li> <li>Operate the unit at low speed (MIN.).</li> <li>Temporarily switch to the intermittent mode.</li> <li>Temporarily use a humidifier.</li> </ul>
6.	Air too cold at the air supply grille.	<ul style="list-style-type: none"> <li>Make sure the outside hoods are not blocked.</li> <li>Operate the unit at low speed (MIN.).</li> <li>Have the system balancing checked.</li> <li>Have the unit defrost system checked.</li> <li>Install a duct heater.</li> </ul>

### REPLACEMENT PARTS AND REPAIR:

In order to ensure your ventilation unit remains in good working condition, you must use the manufacturer genuine replacement parts only. The manufacturer replacement parts are specially designed for each unit and are manufactured to comply with all the applicable certification standards and maintain a high standard of safety. Any third party replacement part used may cause serious damage and drastically reduce the performance level of your unit, which will result in premature failing. The manufacturer recommends to contact a certified service depot for all replacement parts and repair.