



vănEE 90H-V

Part no. 1601630

67 to 157 CFM (0.4 in. w.g.)



VB0125

THE NEWEST ADDITION TO OUR POPULAR BRONZE FAMILY

The contractor's priority is to offer affordable improved indoor air quality to the customer. At vănEE, we also share this vision: provide a reliable product that will ensure the homeowner a healthier environment. The 90H-V offers all the basic features for the new construction market, such as integrated balancing dampers and a defrosting system without negative pressure. Moreover, all aspects of its design were thought to ease balancing of air flow and simplify installation; it also offers easy access to electronic components.

Design with 2 PSC motors, the 90H-V improves indoor air quality and reduces excess humidity, ensuring a continuous supply of fresh air from outside into the house.

- Faster and easier installation of insulated flexible ducts with practical straps
- Integrated balancing dampers
- Easy to access electronic module
- Homeshield™ defrosting system (no negative pressure)
- Heat recovery core offers greater comfort
- Design with 2 PSC high pressure blowers
- Integrated draining system with antimicrobial coating
- ENERGY STAR® qualified

REPAIRS AND MAINTENANCE

The 90H-V low power consumption PSC motors are permanently lubricated. The electronic circuit board eliminates electromechanical parts, reducing repair time to a minimum.

WARRANTY

The 90H-V unit is protected by a complete 2-year warranty on all parts. The heat recovery core is covered by a limited lifetime warranty, with the original proof of purchase.

Available at:

HEAT RECOVERY VENTILATOR

Controls

- This unit is very simple to operate. Once it is installed, press on its push button, located under the unit, to activate it. Press once for low speed, once again for high speed, and once more to stop it.
- The following main controls are also available:
 - Lite-Touch Bronze no. 40270
 - Bronze no. 40250
- Also, 1 to 5 of the following optional controls can be added:
 - 20-min. Lighted push button no. 1806110
 - 60-min. Mechanical timer no. 00910

Options

- Complete line of registers and diffusers
- Electric duct heater

Homeshield™ Defrosting System

The 90H-V uses a unique defrosting method. No negative pressure is created by air exhausted to the outside, as the air is recirculated into the house, helping to prevent any backdraft.

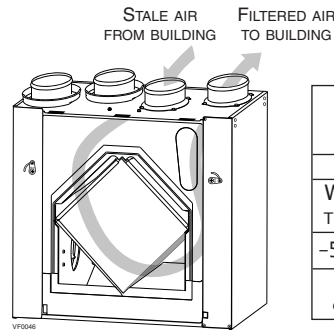

OUTSIDE TEMPERATURE		DEFROST CYCLE DEFROSTING MIN./ OPERATING MIN.
°C	°F	
WARMER THAN -5	WARMER THAN 23	NO DEFROST
-5 TO -27	23 TO -17	7/25
-27 & LESS	-17 & LESS	10/22

Heat Recovery Core

Dimensions: 10" x 10" x 14.25" (25.4 cm x 25.4 cm x 36.2 cm)

Exchange surface: 100 ft² (9.3 m²)

Weight: 7.26 lb (3.3 kg)

Material: Polypropylene

Type: Cross flow

Warranty: Limited lifetime

Requirements and Standards

- Complies with the UL 1812 requirements regulating the installation of Heat Recovery Ventilators
- Complies with the CSA C22.2 no. 113 Standard applicable to ventilators
- Complies with CSA C444 requirements regulating the installation of Heat Recovery Ventilators
- Technical data was obtained from published results of tests relating to CSA C439 Standards
- HVI certified and ENERGY STAR® qualified

Dimensions and Service Clearances: vänEE 90H-V

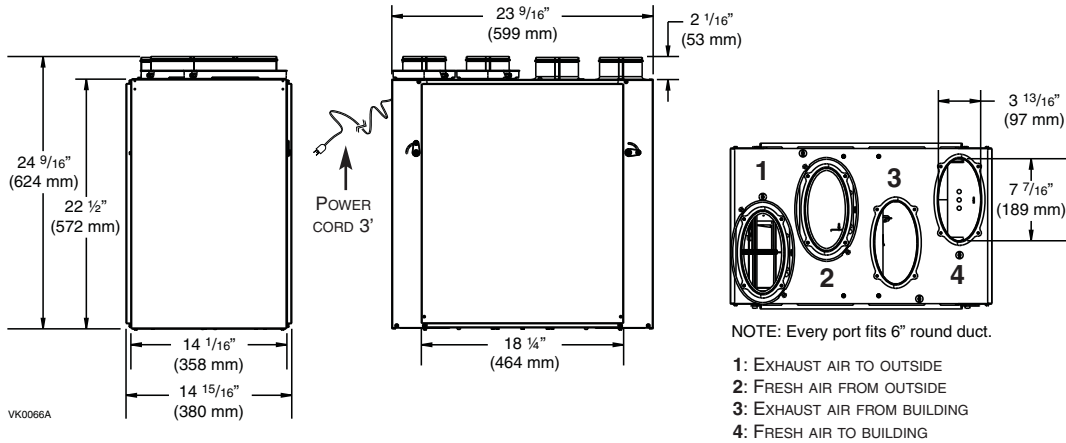

Ventilation Performance

EXT. STATIC PRESSURE		NET SUPPLY AIR FLOW			GROSS AIR FLOW					
					SUPPLY			EXHAUST		
Pa	in. w.g.	l/s	cfm	m ³ /h	l/s	cfm	m ³ /h	l/s	cfm	m ³ /h
25	0.1	91	193	328	92	195	331	91	194	328
50	0.2	86	182	310	86	183	310	86	182	310
75	0.3	80	170	288	81	171	292	80	169	288
100	0.4	74	157	266	74	158	266	74	157	266
125	0.5	67	142	241	67	143	241	69	147	248
150	0.6	62	132	223	62	133	223	63	133	227
175	0.7	55	117	198	56	118	202	57	120	205
200	0.8	47	101	169	48	101	173	49	104	176
225	0.9	40	86	144	41	87	148	43	92	155
250	1.0	33	71	119	34	71	122	35	74	126

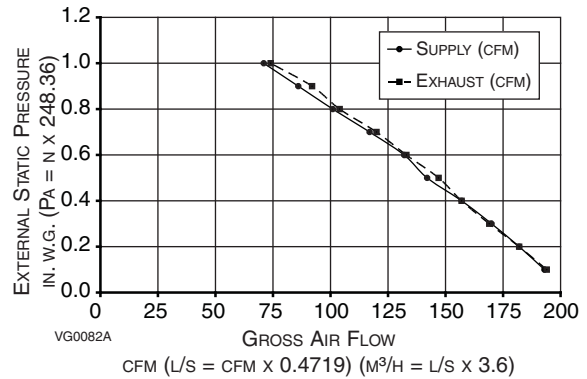

Energy Performance

SUPPLY TEMPERATURE		NET AIR FLOW		POWER CONSUMED	SENSIBLE RECOVERY EFFICIENCY	APPARENT SENSIBLE EFFECTIVENESS	LATENT/RECOVERY MOISTURE TRANSFER
°C	°F	L/S	CFM	WATTS			
HEATING							
0	32	32	67	56	70	78	0.00
0	32	40	86	64	68	75	0.01
0	32	56	120	86	64	70	0.01
-25	-13	30	63	79	61	83	0.01

NOTE: All specifications are subject to change without notice.

Specifications and Ratings

- Model: 90H-V
- Part Number: 1601630
- Total assembled weight (including polypropylene core): 52.0 lb (23.6 kg)
- Oval shaped ports; fit 6" round ducts
- Drains: 1/2" (1.2 cm) fittings with 10 ft (3 m) PVC drain
- Core filters: 2 washable Merv 7 9.2" x 14.25" x 3.8" (23.4 x 36.2 x 9.6 cm)
- Insulation: Expanded polystyrene
- Mounting: Suspension by chains and springs
- Supply and Exhaust blower motors: 2 PSC motors
 - Protection type: Thermally protected
 - Insulation class: F
- Speed control on unit:
 - Low and High speed.
 - Other modes available with Lite-Touch main control.
- Housing: Pre-painted steel
- Heat recovery core:
 - Heat exchange surface area: 100 ft² (9.3 m²)
 - Type: Cross flow
 - Material: Polypropylene
- Unit electrical characteristics:

Volts	Frequency	Ampere	Watts
120	60 Hz	1.0	125

PROJECT:	REMARKS
LOCATION:	
MODEL NO.:	
QTY.:	
SUBMITTED BY: DATE:	



550 Lemire Blvd., Drummondville, QC, Canada J2C 7W9 - Tel.: 1-800-567-3855 Fax: 1-800-567-1715



www.vanee-ventilation.com

11/01

PRODUCT SHEET NO. 91418