



Bronze Series

vånEE 190H

Part no. 1601608

128 to 208 CFM (0.3 in. w.g.)

117 to 189 CFM (0.4 in. w.g.)

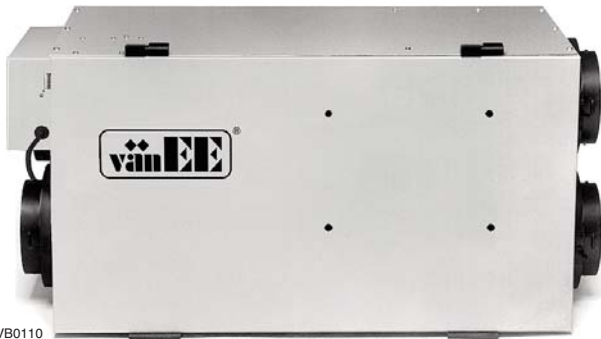

VB0110

BRONZE SERIES: PERFECT FOR NEW RESIDENTIAL CONSTRUCTIONS

The contractor's priority is to offer affordable improved indoor air quality to the customer. The vånEE Bronze Series is an entry level product that offers all the basic features for the new construction market, such as a small-sized housing, integrated balancing damper and a no negative pressure defrost that ensures quick installation and trouble-free operation. Moreover, its operation can be interlocked with an existing furnace without adding an extra relay. Best price for builders and contractors requiring simple, affordable and reliable products.

- **New removable terminal block:** To ease optional wall controls connection
- **Microprocessors:** A proven technology known for its reliability which allows the elimination of numerous electromechanical parts that are most likely to break down

REPAIRS AND MAINTENANCE

All parts of the vånEE 190H that could need maintenance can be removed in less than 5 minutes, allowing direct access for easy repairs. The PSC motor is permanently lubricated.

WARRANTY

The vånEE 190H HRV is protected by a 2-year warranty on parts only. The heat recovery core is covered by a limited lifetime warranty.

Available at:

HEAT RECOVERY VENTILATOR

Controls

- This unit is very simple to operate: once it is installed, press on its push button, located on the electrical compartment, to activate it. Press once for low speed, once again for high speed and once more to stop it.
- For more convenience, the following main controls are available:
 - Lite-Touch Bronze no. 40270
 - Bronze no. 40250
- One or more of the following optional controls can be added:
 - Humidity Control no. 200694
 - 60-min. mechanical timer no. 00910
 - 20-min. lighted push button no. 1806110

Options

- Complete line of registers and diffusers
- Electric duct heater

Homeshield™ Defrosting System

The Bronze Series uses a unique defrosting method. No negative pressure is created by air exhausted to the outside, as the air is recirculated into the house, helping to prevent any backdraft.

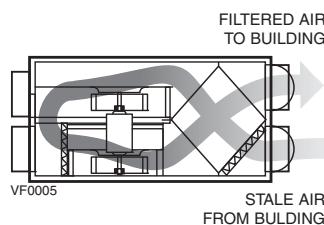

OUTSIDE TEMPERATURE		DEFROST CYCLE DEFROSTING MIN./ OPERATING MIN.
°C	°F	
WARMER THAN -5	WARMER THAN 23	NO DEFROST
-5 TO -27	23 TO -17	6/32
-27 & LESS	-17 & LESS	6/20

Heat Recovery Core

Dimensions: 12" x 14" x 15½" (30.5 cm x 35.5 cm x 39.4 cm)

Exchange surface: 102 ft² (9.54 m²)

Weight: 6.2 lb (2.8 kg)

Material: Polypropylene

Type: Crossflow core

Warranty: Limited lifetime

Requirements and Standards

- Complies with the UL 1812 requirements regulating the installation of Heat Recovery Ventilators
- Complies with the CSA C22.2 no. 113 Standard applicable to ventilators
- Complies with CSA F326 requirements regulating the installation of Heat Recovery Ventilators
- HVI certified
- Technical data was obtained from published results of tests relating to CSA C439 Standards

Dimensions and Service Clearances: v^{an}EE 190H

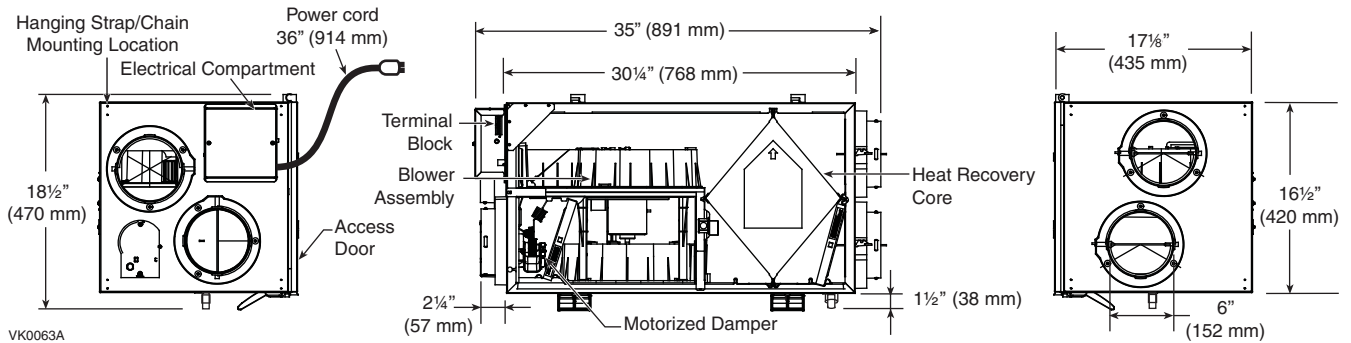

Ventilation Performance

EXT. STATIC PRESSURE	NET SUPPLY AIR FLOW		GROSS AIR FLOW							
			SUPPLY			EXHAUST				
Pa	in. w.g.	l/s	cfm	m ³ /h	l/s	cfm	m ³ /h	l/s	cfm	m ³ /h
25	0.1	110	234	396	112	237	403	112	237	403
50	0.2	103	219	374	105	223	378	106	225	382
75	0.3	98	208	353	100	211	360	99	210	356
100	0.4	89	189	320	91	192	328	91	193	328
125	0.5	84	177	302	85	180	306	82	174	295
150	0.6	71	151	256	72	153	259	70	149	252
175	0.7	64	136	230	65	138	234	44	94	158

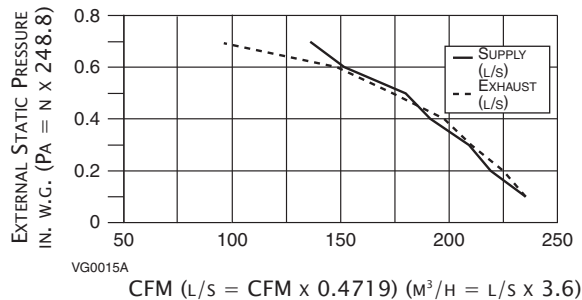

Energy Performance

SUPPLY TEMPERATURE		NET AIR FLOW			POWER CONSUMED WATTS	SENSIBLE RECOVERY EFFICIENCY	APPARENT SENSIBLE EFFECTIVENESS	LATENT/RECOVERY MOISTURE TRANSFERT
°C	°F	L/s	CFM	M ³ /H				
HEATING								
0	32	31	66	112	85	69	81	-0.01
0	32	56	119	202	124	60	70	-0.01
0	32	86	182	310	197	53	62	-0.01
-25	-13	34	72	133	114	62	80	0.08
COOLING								
35	95	-	-	-	-	TOTAL RECOVERY EFFICIENCY		
35	95	-	-	-	-	NOT TESTED		

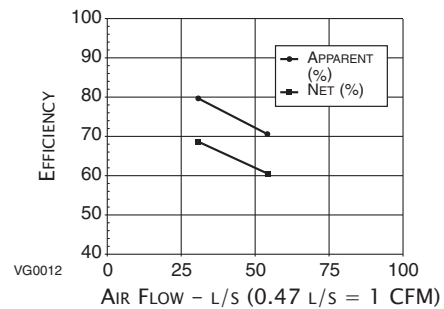

NOTE: All specifications are subjected to change without notice.

Specifications and Ratings

- Model: 190H
- Part Number: 1601608
- Total assembled weight including polypropylene core: 67 lb (30.5 kg)
- Supply & Exhaust air duct connections: 6" (15.24 cm) diameter
- Drains: 1/2" (1.2 cm) fittings with 10 ft (3 m) PVC drain
- Filters: 15 ppi washable reticulated foam 15.375" x 7.125" x 0.75" (39 cm x 18 cm x 1.9 cm)
- Housing: Pre-painted steel
- Insulation: 1" (2.54 cm) aluminum foil faced fiberglass 0.825" (2.10 cm) expanded polystyrene
- Mounting: Suspension by chains and springs
- Supply & Exhaust blower motor: 1 motor
 - Protection type: Thermally protected
 - Insulation class: B
 - V (motor marking): 120 VAC, 60 Hz, 1.7 A, 1040/1300/1630 RPM
- Fan speed control:
 - Low, increased low & high speed
 - Two speeds available to user
 - Low or increased low speed is selected at the time of installation
- Heat recovery core:
 - Heat exchange surface area: 102 ft² (9.54 m²)
 - Type: Crossflow
 - Material: Polypropylene
- Unit electrical characteristics:

Volts	Freq.	Amps	Watts
120	60 Hz	2.1	240

PROJECT:	REMARKS
LOCATION:	
MODEL NO.:	
QTY.:	
SUBMITTED BY:	DATE:



550 Lemire Blvd., Drummondville, QC, Canada J2C 7W9 - Tel.: 1-800-567-3855 Fax: 1-800-567-1715



www.vanee-ventilation.com

11/07

PRODUCT SHEET NO. 90194