



*Gold Series*

## vănEE 1001 HRV

Part no. 43828

71 to 163 CFM (0.3 in. w.g.)

64 to 146 CFM (0.4 in. w.g.)



VB0024

### FOR RENOVATION AND CUSTOM BUILT HOUSES

Designed for homeowners seeking the best performance, added value, quality and a longer warranty. Recognized for its unsurpassed quality and superior craftsmanship, the Gold Series reflects a new level of exceptional performance. It is guaranteed to satisfy the homeowner looking for durability, reliability and performance. The Gold Series: The best of the vănEE experience.

#### Solid Performances

- Best heat recovery in its category
- Best airflow range in its category
- Exclusive convertible HRV to an ERV (Latent Recovery Core)
- Gold Series blower design makes the unit quieter than ever

#### Superior Craftsmanship

- External electrical access side panel
- Integrated balancing dampers
- All parts removable in 5 minutes
- Aluminum framed foam filter
- Improved sliding system for core insertion
- Exclusive, deeper one piece condensation tray to prevent water leakage
- No sharp angles on metal parts
- Exclusive, reinforced housing
- Improved defrost damper and damper mechanism, designed to operate during the toughest weather conditions

#### Tradition of Quality

- Proven technology and mechanical simplicity for heat recovery
- Low motor temperature operation for longer life expectancy
- 5-year warranty
- ENERGY STAR® qualified

Available at:

## HEAT RECOVERY VENTILATOR

### Controls and options

- Our main control Platinum (no. 40460) allows you to manage your ventilation with a programmable mode. This control also features our fully automated optimizer mode called the Smart mode.
- The following main control is also available:
  - Basic no. 40210
- One or more of the following optional controls can also be added:
  - Humidity control no. 200694
  - 20/40/60-minute push button no. 03701
  - 60-minute mechanical timer no. 00910
- Integrated furnace interlock relay
- Complete line of registers and diffusers available
- Electric duct heater

### No Negative Pressure Defrost

Defrost system ensures that no negative pressure is created by air exhausted to the outside, as the air is recirculated into the house, helping to prevent any backdraft.

OUTSIDE TEMPERATURE		DEFROST CYCLE DEFROSTING MIN./ OPERATING MIN.
°C	°F	
WARMER THAN -5	WARMER THAN 23	No DEFROST
-5 TO -30	23 TO -22	6/32
-30 & COLDER	-22 & COLDER	6/20

### Heat Recovery Core

Dimensions: 12" x 12" x 12.875" (30.5 x 30.5 x 32.7 cm)

Exchange surface: 120 ft<sup>2</sup> (11.16 m<sup>2</sup>)

Weight: 8.5 lb (3.85 kg)

Type: Crossflow

Material: Polypropylene

Warranty: Lifetime

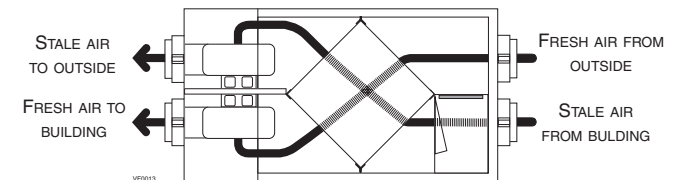

### Requirements and Standards

- Complies with the CSA C22.2 no. 113 Standard applicable to ventilators
- Complies with the CSA C444 requirements regulating the installation of Heat Recovery Ventilators
- Technical data was obtained from published results of tests relating to CSA C429 Standards
- HVI certified and ENERGY STAR® qualified

# Dimensions and Service Clearances: vānEE 1001 HRV

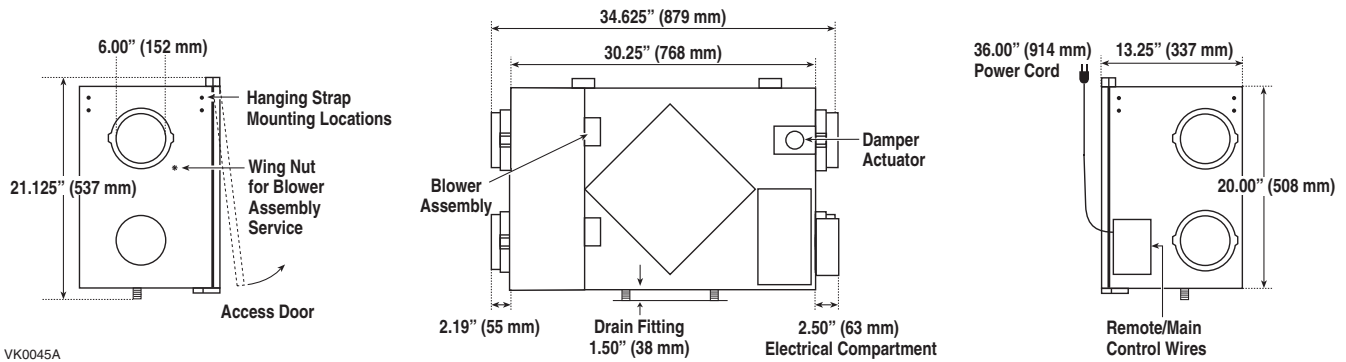

VK0045A

## Ventilation Performance

EXTERNAL STATIC PRESSURE		NET SUPPLY AIR FLOW		GROSS AIR FLOW			
				SUPPLY		EXHAUST	
Pa	in. w.g.	l/s	cfm	l/s	cfm	l/s	cfm
25	0.1	84	77	88	186	90	190
50	0.2	80	169	84	178	86	182
75	0.3	77	163	81	171	81	171
100	0.4	69	146	72	153	76	161
125	0.5	61	130	65	137	66	139
150	0.6	46	98	49	103	52	110
175	0.7	38	81	40	85	32	67

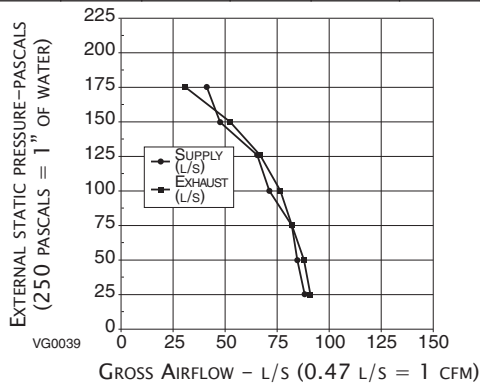

## Energy Performance

SUPPLY TEMPERATURE		NET AIR FLOW		AVERAGE POWER WATTS	SENSIBLE RECOVERY EFFICIENCY	APPARENT SENSIBLE EFFECTIVENESS	LATENT RECOVERY MOISTURE TRANSFER
°C	°F	L/S	CFM				
HEATING							
0	32	28	60	54	75	83	-0.03
0	32	46	97	78	67	74	0.01
0	32	65	138	124	64	72	-1.02
-25	-13	26	55	62	67	89	0.05
COOLING							
35	95				TOTAL RECOVERY EFFICIENCY		
NOT TESTED							

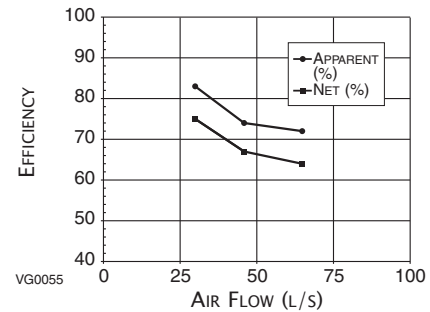

## Specifications

- Model: 1001 HRV
- Part Number: 43828
- Total assembled weight with polypropylene or enthalpic transfer media core: 65 lb (30 Kg)
- Supply air duct connections: 6" diameter
- Exhaust air duct connections: 6" diameter
- Drains: 1/2" fittings
- Filters: 30 ppi washable reticulated foam  
11.75" x 12.87" x 0.75"  
(29.85 x 32.69 x 1.9 cm)

- Housing: Pre-painted steel
- Insulation: 1" aluminum foil faced fiberglass
- Mounting: Reinforced rubber straps (or chain) and hardware provided to suspend unit
- Supply & Exhaust Blower Motors:
  - Bearings: Sleeve bearings
  - Type: PSC

- Fan Speed Control:
  - Low, increased low, high speed
  - Two speeds available to user
  - Low or increased low speed is selected at the time of installation
- Unit Electrical Characteristics:
  - Voltage: 120 V
  - Power: 147 W
  - Current: 1.4 A

NOTE: All specifications are subjected to change to change without notice.

PROJECT:	REMARKS
LOCATION:	
MODEL NO.:	
QTY.:	
SUBMITTED BY:	DATE:



550 Lemire Blvd., Drummondville, QC, Canada J2C 7W9 - Tel.: 1-800-567-3855 Fax: 1-800-567-1715



www.vanee-ventilation.com

11/01

PRODUCT SHEET NO. 90196