

Installation Manual



VB0140

vänEE	VENMAR
2000 HE	1.8 HE
3000 HE	2.6 HE



These products earned the ENERGY STAR® by meeting strict energy efficiency guidelines set by Natural Resources Canada and the US EPA. They meet ENERGY STAR requirements only when used in Canada.

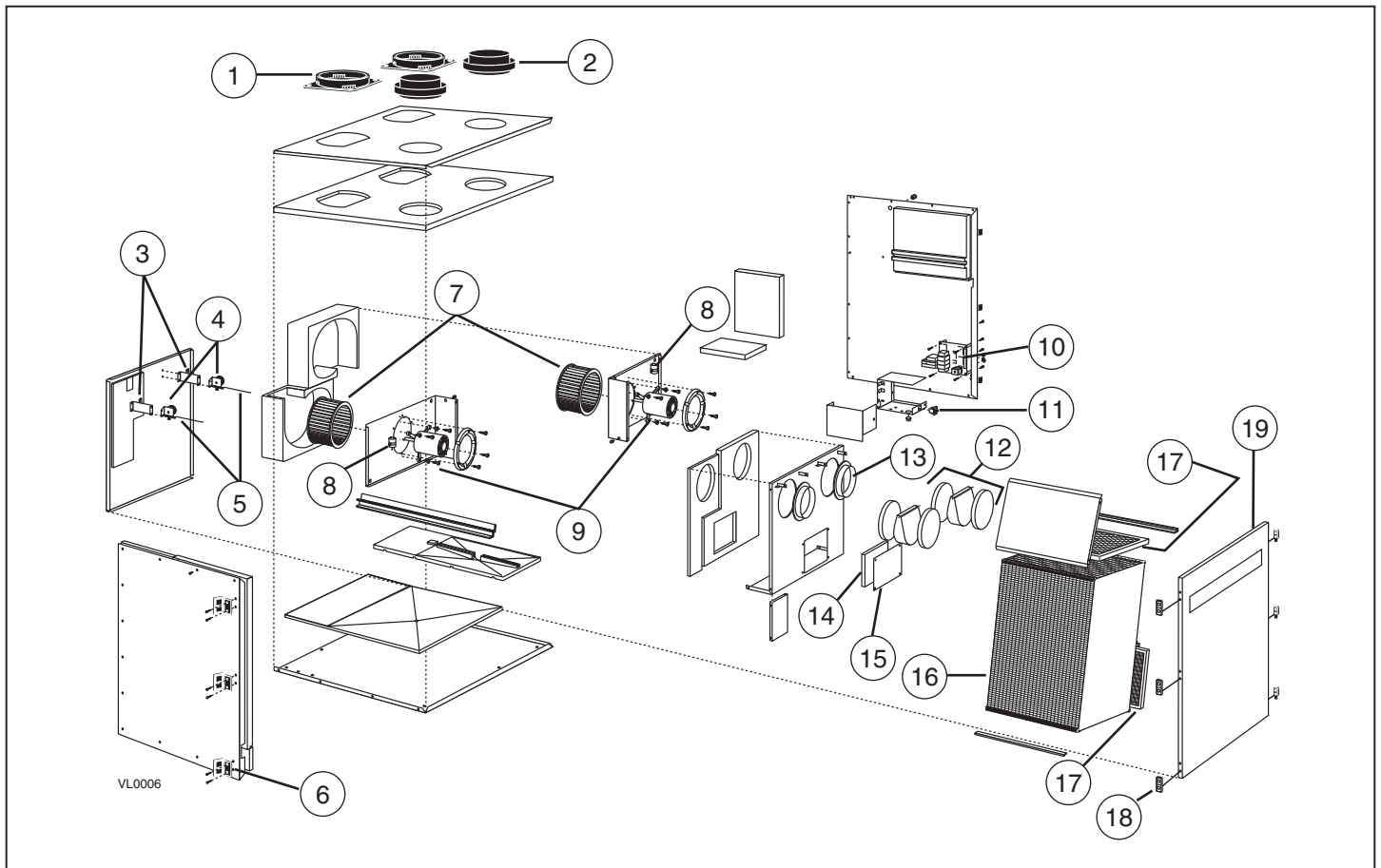

Table of contents

1. Service	3-4
1.1 3D Drawing for Venmar 1.8 HE, Venmar 2.6 HE, vänEE 2000 HE & vänEE 3000 HE	3
1.2 Part Ordering Chart for Venmar 1.8 HE, Venmar 2.6 HE, vänEE 2000 HE & vänEE 3000 HE	4
2. Technical Data	5
2.1 Diagrams of Air Flows	5
2.2 Dimensions	5
2.3 Specifications	5
3. Typical Installations	6
3.1 Fully Ducted System	6
3.2 Exhaust Ducted System (Source Point Ventilation)	6
3.3 Simplified	6
4. Installation	7-12
4.1 Locating and Mounting the Unit	7
4.2 Planning of the Ductwork	7
4.3 Calculating Duct Size	7-8
4.4 Installing Ductwork and Registers	8-10
4.5 Connecting Flexible Duct to the Unit	11
4.6 Installing Exterior Hoods	12
4.7 Connecting the Drain	12
5. Installation of the Controls	13-14
5.1 Main Controls with LCD Screen Installation	13
5.2 All Other Main Controls Installation	14
5.3 Main and Auxiliary Controls Electrical Connection (All Models)	14
6. Electrical Connection to the Furnace	15
7. Furnace Interlock Types	15
8. Wiring Diagram	16
9. Air Flow Balancing	17-18
10. Maintenance	18
10.1 Regular Maintenance	18
10.2 Prolonged Maintenance	18
11. Troubleshooting	19-20
12. References	20

1. Service

1.1 3D DRAWING FOR VENMAR 1.8 HE, VENMAR 2.6 HE, VÄNEE 2000 HE AND VÄNEE 3000 HE



1. Service (suite)

1.2 PARTS ORDERING CHART FOR VENMAR 1.8 HE, VENMAR 2.6 HE, VÄNEE 2000 HE AND VÄNEE 3000 HE

No	Description	Venmar 1.8 HE	Venmar 2.6 HE	vänEE 2000 HE	vänEE 3000 HE
1	Simple Collar 8"	01657	01657	01657	01657
2	Double Collar 6"	00865	00865	00865	00865
3	Damper Assembly Bracket	11233	11233	11233	11233
4	Damper Actuator (6 W)	01295	01295	01295	01295
5	Damper Actuator Rod 7.250"	10905	10905	10905	10905
6	Door Latch	00886	00886	00886	00886
7	Wheel 7.125" DIA. x 3"	01231	————	01231	————
7	Wheel 3.062" DIA. x 3"	————	01263	————	01263
8	Capacitor	02104	02104	02104	02104
9	Motor	12064	12065	12064	12065
10	Electronic Circuit Board	13038	13038	13038	13038
11	Door Switch (SPST), E69 10A	01825	01825	01825	01825
12	Insulated Triangular Damper	12452	12452	12452	12452
13	Single Collar Port no. 5, 6"	01277	01277	01277	01277
14	Motor Panel Insulation	01439	01439	01439	01439
15	Motor Panel	11236	11236	11236	11236
16	Heat recovery Core	04816	04816	04817	04817
17	Filter 8 ¹ / ₈ " x 10 ³ / ₄ " x 7/8"	04771	04771	04771	04771
18	Door Keeper	00887	00887	00887	00887
19	Door Assembly	13433	13433	12661	12661
20	Thermistor (not shown)	12895	12895	12895	12895
21	Drain Connector Kit (2) (not shown)	11937	11937	11937	11937

Please take note that parts not listed are not available; those parts require assembly knowledge that only manufacturer can guarantee.

TO ORDER PARTS: Contact your local distributor

REPLACEMENT PARTS AND REPAIR:

In order to ensure your ventilation unit remains in good working condition, you must use the manufacturer genuine replacement parts only. The manufacturer replacement parts are specially designed for each unit and are manufactured to comply with all the applicable certification standards and maintain a high standard of safety. Any third party replacement part used may cause serious damage and drastically reduce the performance level of your unit, which will result in premature failing. The manufacturer recommends to contact a certified service depot for all replacement parts and repair.

2. Technical Data

2.1 DIAGRAMS OF AIR FLOWS

The direction of the air flow is indicated in each of the following diagrams (Figures 1 and 2). Please note that the stale air never mixes with the fresh air.

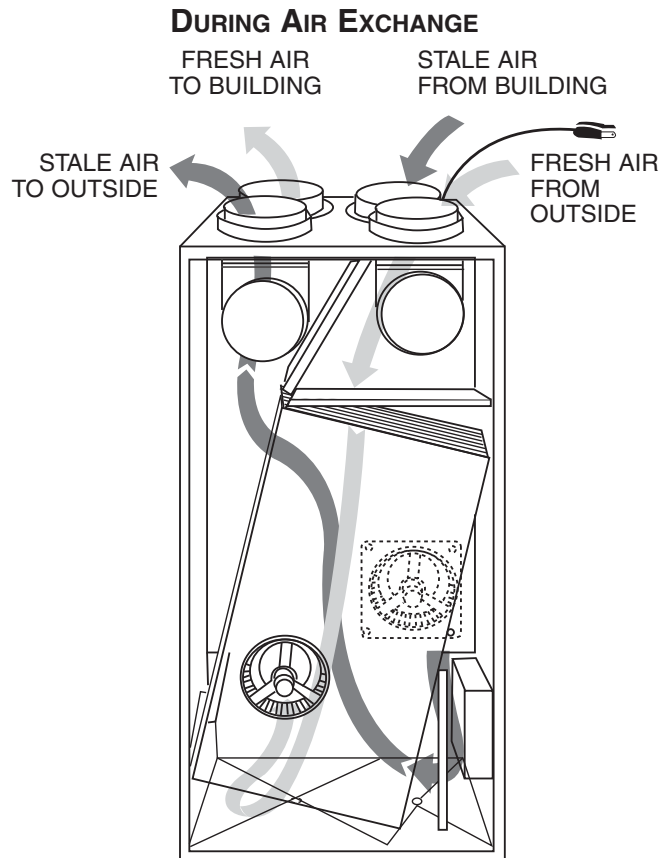

VF0025

Figure 1

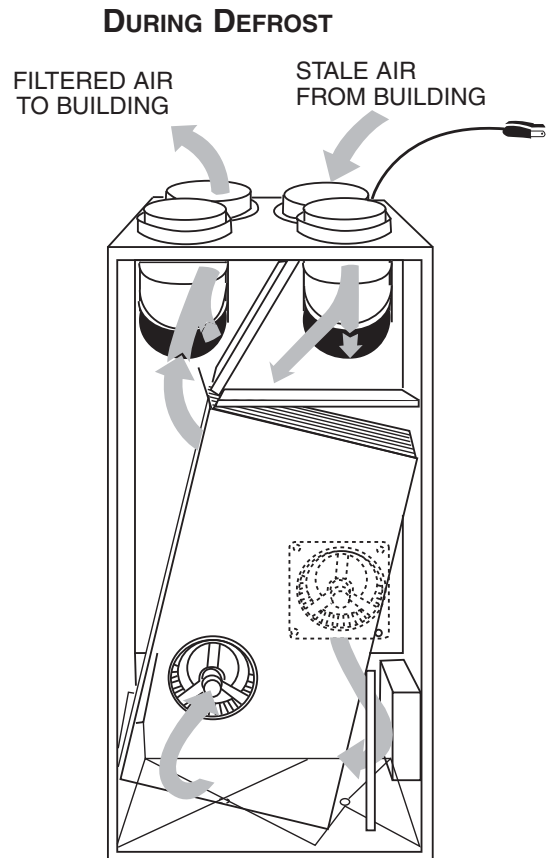

VF0002

Figure 2

2.2 DIMENSIONS

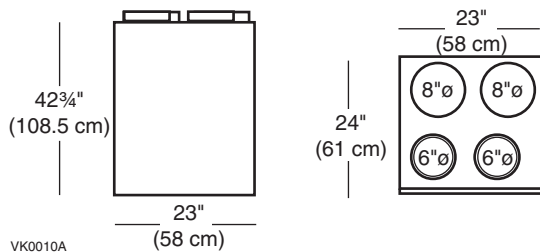

2.3 SPECIFICATIONS

MODELS	VENMAR 1.8 HE AND 2.6 HE, VÄNEE 2000 HE AND 3000 HE
Weight	140 lb (63.5 kg)
Drain diameter	1/2 inch (12 mm)
Installation	Suspension by chains and springs
Electrical supply	120 Volts, 60 Hz
Motor speeds	High and low speeds factory set (opt. increased low speed - red wire)

NOTE: THE VENMAR AND VÄNEE PERFORMANCE CHARTS ARE LISTED ON THE SPECIFICATION SHEETS OF THESE UNITS. TO ACCESS THE VENMAR UNITS SPECIFICATION SHEETS, VISIT WWW.VENMAR.CA, AND TO ACCESS THE VÄNEE UNITS SPECIFICATION SHEETS, VISIT WWW.VANEE-VENTILATION.COM.

3. Typical Installations

3.1 FULLY DUCTED SYSTEM

(Primarily for homes with radiant hot water or electric baseboard heating. See Figure 4.)

Moist, stale air is exhausted from the high humidity areas in the home, such as bathrooms, kitchens and laundry rooms. Fresh air is supplied to bedrooms and principal living areas.

If required, bathroom fans and a range hood may be used to better exhaust stale air.

Homes with more than one level require at least one exhaust register at the highest level.

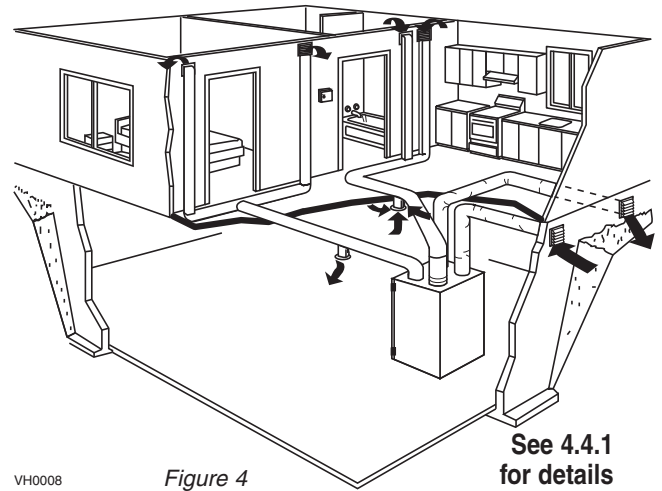

3.2 EXHAUST DUCTED SYSTEM (SOURCE POINT VENTILATION)

(For homes with forced air heating. See Figure 5.)

Moist, stale air is exhausted from the high humidity areas in the home, such as bathrooms, kitchen and laundry room.

Fresh air is supplied to the cold air return or the supply duct of the furnace.

If required, bathroom fans and a range hood may be used to better exhaust stale air.

Homes with more than one level require at least one exhaust register at the highest level.

NOTE: For this type of installation, it is not essential that the furnace blower runs when the unit is in operation, but we recommend it.

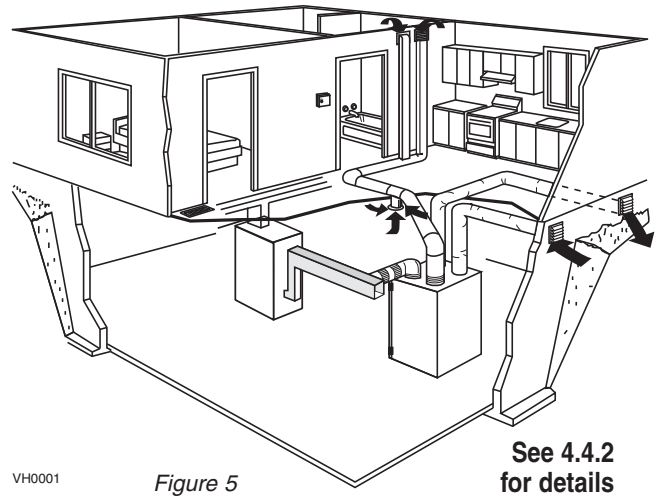

3.3 SIMPLIFIED (VOLUME VENTILATION)

(For homes with forced air heating. See Figure 6 or 7.)

Fresh air and exhaust air flow through the furnace ducts which simplifies the installation.

The use of bathroom fans and range hood is required to better exhaust stale air.

NOTE: For the installation type shown in Figure 7, **furnace blower should be running** when the unit is in operation.

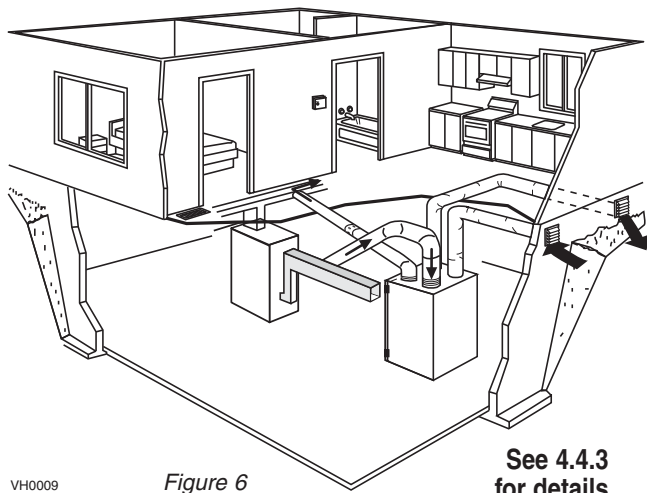

OR

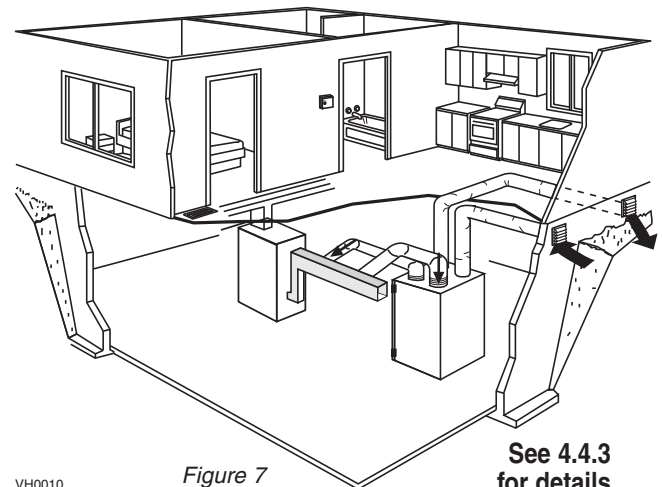

4. Installation

⚠ WARNING

When applicable local regulation comprises more restrictive installation and/or certification requirements, the aforementioned requirements prevail on those of this document and the installer agrees to conform to these at his own expenses.

⚠ WARNING

When performing installation, servicing or cleaning the unit, it is recommended to wear safety glasses and gloves.

INSPECT THE CONTENTS OF THE BOX

- Inspect the **exterior of the unit** for shipping damage. Ensure that there is no damage to the door, door latches, door hinges, dampers, duct collars, cabinet, etc.
- Inspect the **interior of the unit** for damage. Ensure that the fan motor assembly, recovery core, insulation, damper, damper actuator and drain pan are all intact.
- If the unit was damaged during shipping, contact your local distributor. (Claim must be made within 24 hours after delivery.)

4.1 LOCATING AND MOUNTING THE UNIT

Choose an appropriate location for the unit:

- Within a heated area of the house (10°C / 50°F or more), normally the basement (in a furnace room, a laundry room, etc).
- Away from living areas (dining room, living room, bedroom), if possible.
- So as to provide easy access to the interior cabinet and to the control panel in the unit.
- Close to an exterior wall, so as to limit the length of the insulated flexible duct to and from the unit.
- Close to a drain. (If no drain is close by, use a pail to collect run-off.)
- Away from hot chimneys, electrical panel and other fire hazards.
- Allow for a power source (110 V standard outlet).

Hang the unit to ceiling joists with the 4 chains and springs
(See Figure 8).

CAUTION

Make sure the unit is level.

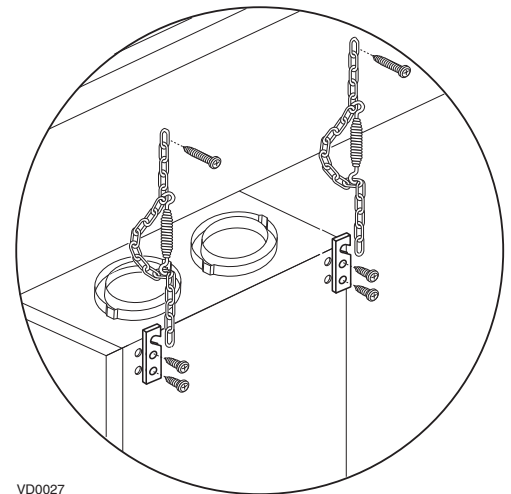

Figure 8

4.2 PLANNING OF THE DUCTWORK

- Follow the instructions in section 4.3 to determine the appropriate duct diameters for your system.
- Keep it simple. Plan for a minimum of bends and joints. Keep the length of insulated duct to a minimum.
- Do not use wall cavities as ducts. Do not use branch lines smaller than 4" Ø (102 mm Ø).
- Do not ventilate crawl spaces or cold rooms. Do not attempt to recover the exhaust air from a dryer or range hood; this would cause clogging of the recovery core. Use sheet metal for the kitchen exhaust duct.
- Be sure to plan at least one exhaust register on the highest lived-in level of the house if it has 2 floors or more.

4.3 CALCULATING DUCT SIZE

Use table beside to ensure that the ducts you intend to install will be supporting airflows at or under the recommended values. Avoid installing ducts that will have to support airflows near the maximum values and never install a duct if its airflow exceeds the maximum value.

Duct Diameter	Recommended Airflow	Maximum Airflow
4" Ø	40 cfm	60 cfm
5" Ø	75 cfm	110 cfm
6" Ø	120 cfm	180 cfm
7" Ø	185 cfm	270 cfm
8" Ø	260 cfm	380 cfm

4. Installation (cont'd)

4.3 CALCULATING DUCT SIZE (CONT'D)

4.3.1 Example for calculation:

Problem: My installation requires two exhaust registers (one for the kitchen, one for the bathroom). I will connect these registers to a main duct connected to the unit (high speed performance value of 140 cfm). What size of duct should I use for the main exhaust duct and for the two end branches leading to the registers? (See Figure 9.)

Solution: Simplified method. (For a more detailed method of calculating duct size refer to ASHRAE HANDBOOK.)

Main duct: Table indicates for a 6"Ø duct: Recommended Airflow: 120 cfm; Maximum Airflow: 180 cfm. The high speed airflow of 140 cfm is close enough to the recommended value (120) and far enough away from the maximum value (180). Therefore a 6"Ø duct or larger is an appropriate choice for the main exhaust duct.

End branches: Each end branch will have to transport an airflow of 70 cfm (140 divided by 2). The table indicates for a 5"Ø duct: Recommended Airflow: 75 cfm; Maximum Airflow: 110 cfm. The high speed airflow of 70 cfm is close enough to the recommended value (75) and far enough away from the maximum value (110). Therefore a 5"Ø duct or larger is an appropriate choice for the 2 end branches.

NOTE: A 4"Ø duct would have been too small because the maximum acceptable value for a 4"Ø duct is 60 cfm.

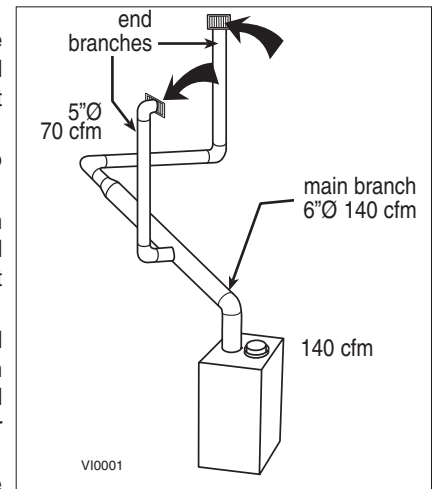

Figure 9

4.3.2 Example of a design for a fully ducted system for a unit having a high speed performance of 222 cfm (see Figure 10).

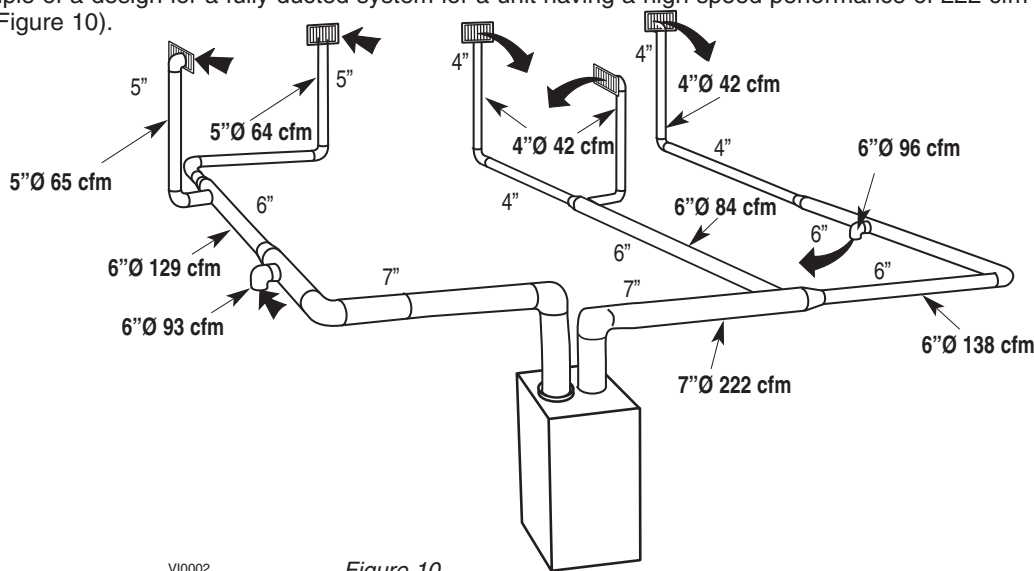

Figure 10

4.4 INSTALLING DUCTWORK AND REGISTERS

⚠ WARNING

Never install a stale air exhaust register in a room where a combustion device is, such as a gas furnace or a gas water heater or a fireplace.

CAUTION

The ductwork is intended to be installed in compliance with all local and national codes that are applicable.

4.4.1 Fully Ducted System (as illustrated in section 3.1)

Stale air exhaust ductwork:

- Install registers in areas where contaminants are produced: kitchen, bathrooms, laundry rooms, etc.
- Install registers at 6 to 12 inches (152 to 305 mm) from the ceiling on an interior wall OR install them in the ceiling.
- Install the kitchen register at least 6 feet (1.8 m) from the oven.
- If possible, measure the velocity of the air flowing through the registers. If the velocity is higher than 400 ft/min then the register type is too small. Replace it with a larger one.

4. Installation (cont'd)

4.4 INSTALLING DUCTWORK AND REGISTERS (CONT'D)

4.4.1 Fully Ducted System (as illustrated in section 3.1) (cont'd)

Fresh air distribution ductwork:

- Install registers in bedrooms, dining room, living room and basement.
- Install registers either in the ceiling or high on the walls with air flow directed toward the ceiling. (The cooler air will then cross the upper part of the room, and mix with room air before descending to occupants level.)
- If a register must be floor installed, direct the airflow toward the wall.

4.4.2 Exhaust Ducted System (Source Point Ventilation) (see illustration, section 3.2)

Stale air exhaust ductwork: (same as for Fully Ducted System, section 4.4.1)

Fresh air distribution:

⚠ WARNING

When performing duct connection to the furnace, installation must be done in accordance with all applicable codes and standards. Please refer to your local building code.

CAUTION

When performing connection to the furnace supply duct, this duct must be sized to support the additional airflow produced by the HRV. Also, use a metal duct. It is recommended that the HRV is running when the furnace is in operation to prevent backdrafting inside the HRV.

There are two methods for connecting the unit to the furnace:

Method 1: supply side connection

- Cut an opening into the furnace supply duct at least 18" (0.5 m) from the furnace.
- Connect this opening to the fresh air distribution port of the HRV (use metal duct, see Figure 11).
- Make sure that the HRV duct forms an elbow inside the furnace ductwork.
- If desired, interlock (synchronize) the furnace blower operation with the HRV operation. (See Section 6.)

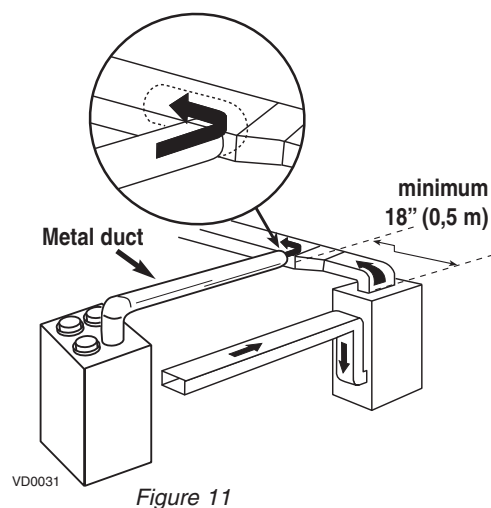

Method 2: return side connection

- Cut an opening into the furnace return duct not less than 10 feet (3.1 m) from the furnace (A+B+C).
- Connect this opening to the fresh air distribution port of the HRV (see Figure 12).

NOTE: For Method 2, it is not essential that the furnace blower runs when the unit is in operation, but we recommend it. If desired, interlock (synchronize) the furnace blower operation with the HRV operation. (See Section 6.)

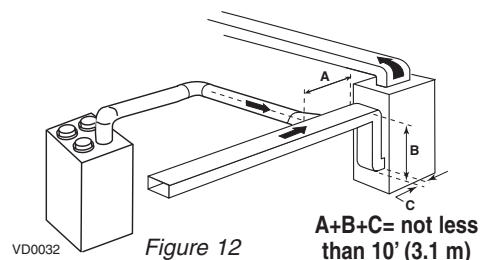

4. Installation (cont'd)

4.4 INSTALLING DUCTWORK AND REGISTERS (CONT'D)

4.4.3 Simplified installation (Volume Ventilation) (see illustration, section 3.3)

⚠ WARNING

When performing duct connection to the furnace, installation must be done in accordance with all applicable codes and standards. Please refer to your local building code.

CAUTION

When performing duct connection to the furnace ducts (Method 1), these ducts must be sized to support the additional airflow produced by the HRV. Also, the supply duct must be a metal duct. It is recommended that the HRV is running when the furnace is in operation to prevent backdrafting inside the HRV.

There are two methods (Figures 13 and 14) for connecting the unit to the furnace:

Method 1: return-supply

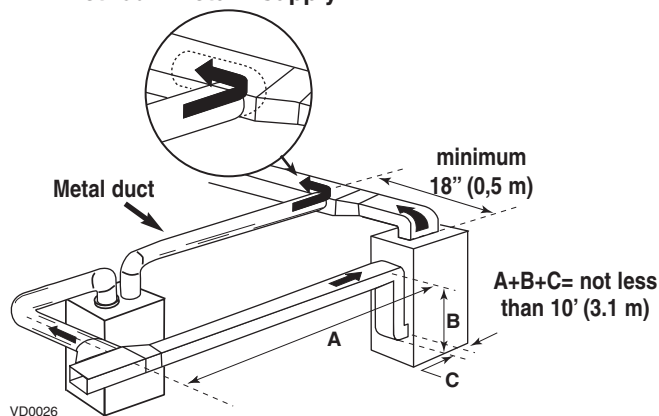

Figure 13

Method 2: return-return

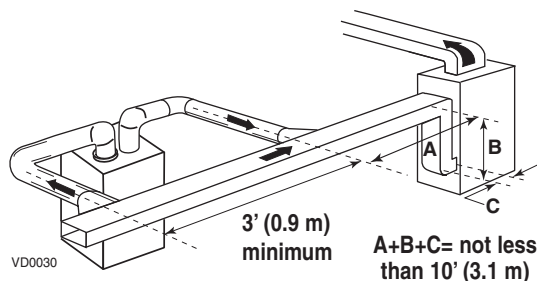

Figure 14

Stale air intake:

- Cut an opening into the furnace return duct (not less than 10' (3.1 m) from the furnace (A+B+C)).
- Connect this opening to the stale air intake port on the HRV as shown.

CAUTION

If using Method 2, make sure the furnace blower operation is synchronized with the unit operation! See Section 6.

Fresh air distribution: (same instructions as for Method 1 or Method 2, section 4.4.2).

For method 2 (return-return) make sure there is a distance of at least 3 feet (0.9 m) between the 2 connections to the furnace.

NOTE: For Method 1, it is not essential to synchronize the furnace blower operation with the unit operation, but we recommend it.

4. Installation (cont'd)

4.5 CONNECTING FLEXIBLE DUCTS TO THE UNIT

4.5.1 For models vänEE 2000 HE and Venmar 1.8 HE

Use the following procedure for connecting the insulated flexible duct to the ports on the unit (exhaust to outside and fresh air from outside).

- Pull back the insulation to expose the flexible duct.
- Connect the interior flexible duct to the opening using a duct tie.
- Carefully seal the connection with duct tape.
- Pull the insulation over the joint and tuck it between the inner and outer rings of double collar.
- Pull the vapor barrier over the insulation and over the outer ring of the double collar.
- Apply duct tape to the joint making an airtight seal. Avoid compressing the insulation when pulling the tape tightly around the joint. A compressed insulation loses its R value and also causes water dripping due to condensation on the exterior surface of the duct.

CAUTION

Make sure that the vapor barrier on the insulated ducts does not tear during installation.

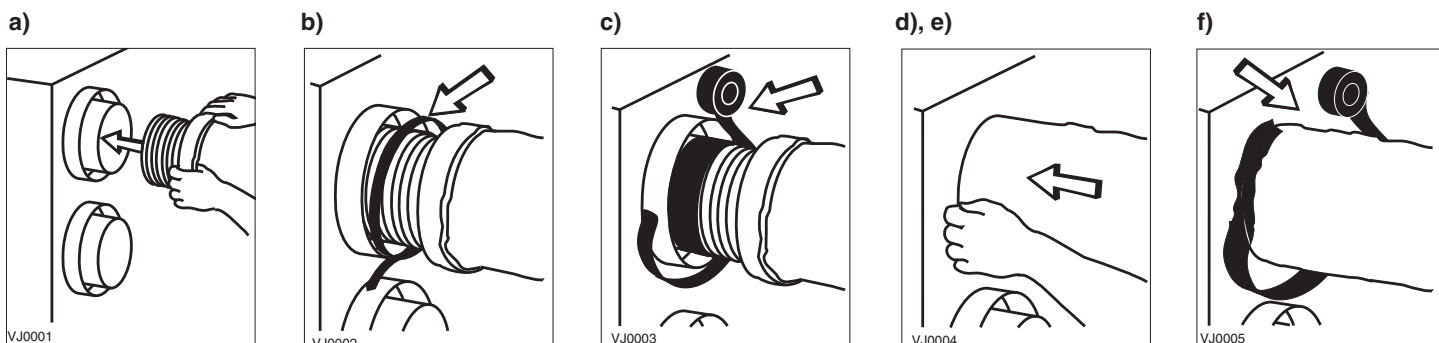

4.5.2 For models Venmar 2.6 HE and vänEE 3000 HE

Use the following procedure for connecting the insulated flexible duct to the ports on the unit (exhaust to outside and fresh air from outside).

NOTE: To obtain the performances shown on technical data, use 8" ducts and exterior ports to connect the unit to the exterior hoods.

- Install the 6" to 8" transition on the 6" ports of the unit and seal with duct tape.
- Pull back the insulation to expose the flexible duct. Connect the interior flexible duct to the transition using a duct tie.
- Carefully seal the connection with duct tape.
- Pull the insulation over the joint and tuck it between the inner and outer rings of double collar.
- Pull the vapor barrier over the insulation and over the outer ring of the double collar.
- Apply duct tape to the joint making an airtight seal. Avoid compressing the insulation when pulling the tape tightly around the joint. A compressed insulation loses its R value and also causes water dripping due to condensation on the exterior surface of the duct.

CAUTION

Make sure that the vapor barrier on the insulated ducts does not tear during installation.

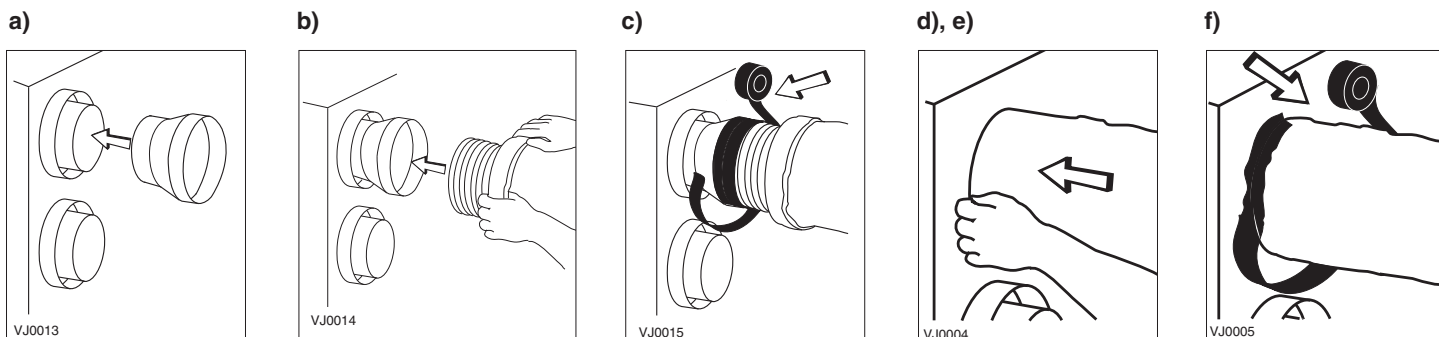

4. Installation (cont'd)

4.6 INSTALLING EXTERIOR HOODS

Choose an appropriate location for installing the exterior hoods:

- At a distance of at least 6 feet (1.8 m) one from the other
- At a distance of 18 inches (457 mm) from the ground

Make sure the intake hood is at least 6 feet (1.8 m) away from any of the following:

- Dryer exhaust, high efficiency furnace vent, central vacuum vent
- Gas meter exhaust, gas barbecue-grill
- Any exhaust from a combustion source
- Garbage bin and any other source of contamination

Refer to Figure 15 for connecting the insulated ducts to the hoods. Place sticker "FRESH AIR INTAKE", provided in installation kit, on corresponding hood.

An "Anti-Gust Intake Hood" should be installed in regions where a lot of snow is expected to fall.

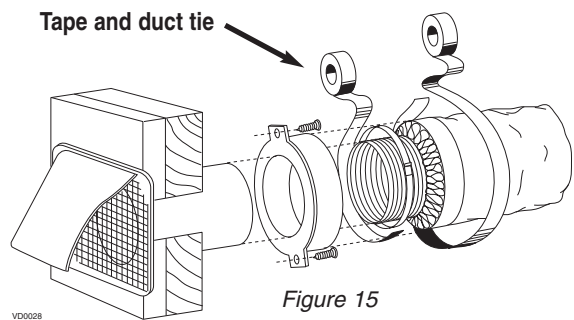
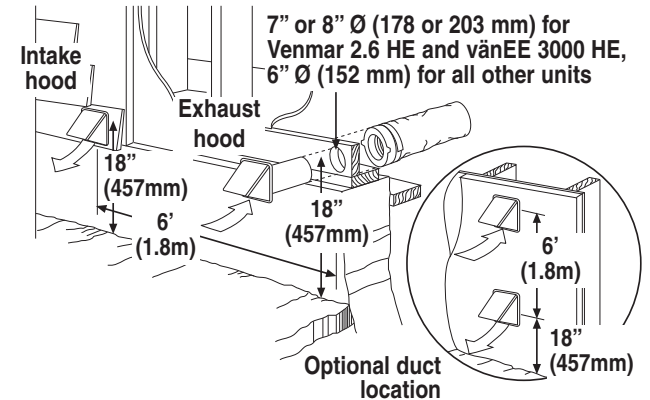
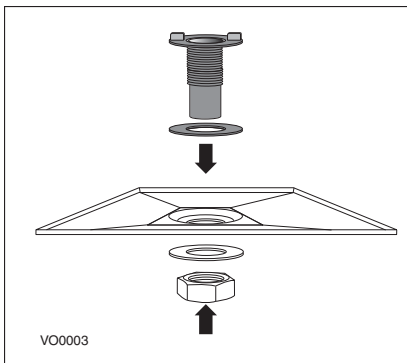
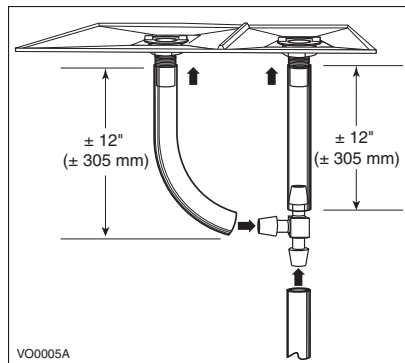

Figure 15

4.7 CONNECTING THE DRAIN



Attach the 2 plastic drain fittings to the unit using the gaskets, washers and nuts as shown.



Cut 2 sections of plastic tubing, about 12" (305 mm) long and attach them to each drain fitting. Join these 2 short sections to the "T" junction and main tube as shown.

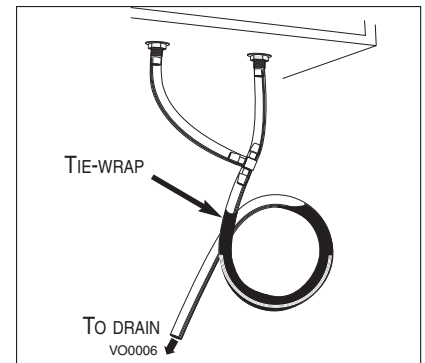

Make a water trap loop in the tube to prevent the unit from drawing unpleasant odors from the drain source. Make sure this loop is situated **BELOW** the "T" as shown. This will prevent water from being drawn back up into the unit in case of negative pressure. Run the tubing to the floor drain or to an alternative drain pipe or pail. Be sure there is a slight slope for the run-off.

If using a pail to collect water, locate the tube end approximately 1" from the top of the pail in order to prevent water from being drawn back up into the unit.

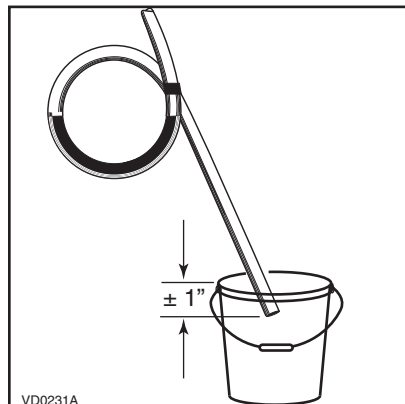

5. Installation of the Controls

WARNING

Always disconnect the unit before making any connections. Failure in disconnecting power could result in electrical shock or damage of the wall control or electronic module inside the unit.

CAUTION

Failure to comply with the following can cause erratic operation of the unit:

- Never install more than one optional wall control per unit.
- Keep control low voltage wiring at least 1 foot (305 mm) away from motors, lighting ballast, light dimming circuit and power distribution panel. Do not route control wiring alongside house power wiring.
- Ensure the wires are securely connected.

NOTE: Since this manual is not dedicated to a specific trade mark, this section will cover only the broad lines of main control installation. For more information about specific features of the main control you will install, refer to the specification (or installation) sheet of this product. The following illustrations are typical ones, the main control you will install may look and be different.

5.1 MAIN CONTROLS WITH LCD SCREEN INSTALLATION

1. Route the cable from the unit to a convenient location for the wall control.

2. Detach the front module from the mounting plate by pulling the bottom part.

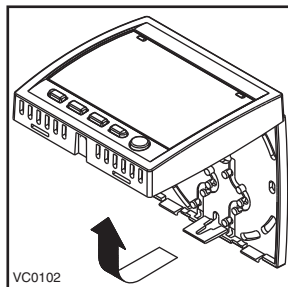

3. Run the cable (4 wires) through the central opening of the mounting plate and mount this plate to the wall using screws (not included). If needed, use wall anchors (not included).

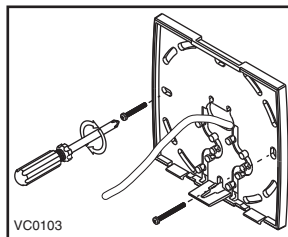

4. Splice back the end of the cable to access the 4 wires. Strip the end of each wire. Connect each wire to its corresponding terminal on the back of the front module: YELLOW wire to "Y", RED wire to "R", GREEN wire to "G" and BLACK wire to "B".

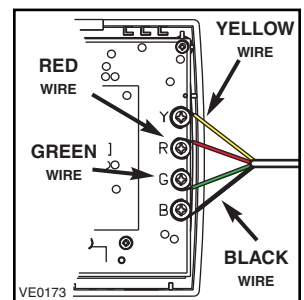

CAUTION

Be careful not to pinch wires when reinstalling the front module on its back plate.

5. Reinstall the front module over the back plate.

5. Installation of the Controls (cont'd)

5.2 ALL OTHER MAIN CONTROLS INSTALLATION

- 1- Determine the location of the control

The wall control must be installed in a central location on the main floor. Typical locations for this control are kitchens, main hallways and family rooms.

- 2- Remove the buttons and the cover plate of the control (see figure beside).

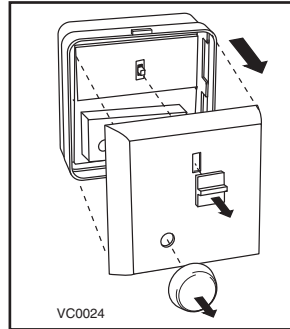

- 3- Install the wall control at approximately 60 inches (1.5 m) from the ground floor of the house.

Use the template provided in the control box to position the wire hole and the screw holes.

Use the screws and the plastic shields provided in the installation kit to secure the control to the wall.

- 4- Connect the wires to the main control (see figure beside.)

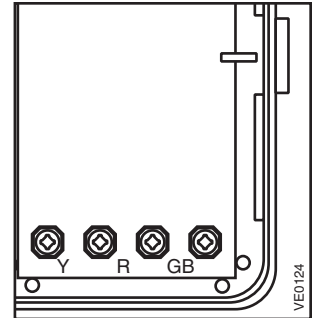

- 5- Reinstall cover plate and buttons.

5.3 MAIN AND AUXILIARY CONTROLS ELECTRICAL CONNECTION (ALL MODELS)

- 1- Connect the wires to their corresponding positions inside the unit. Make sure the connection at the unit and at the control(s) correspond exactly (see figure below.)

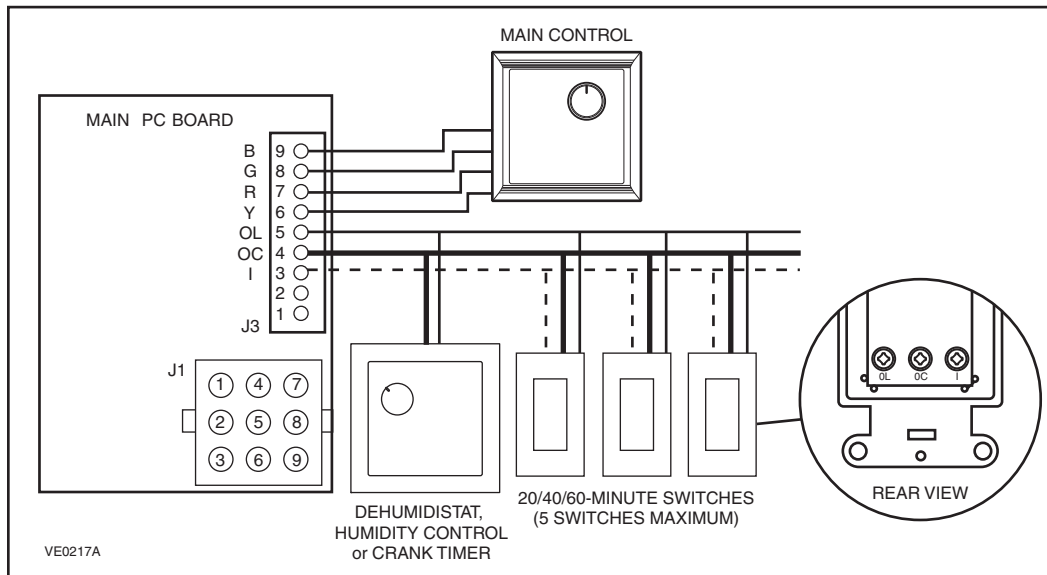

- 2- Plug in the unit and do the "overall verification" of the system.

NOTE: During the verification of a main control, make sure that all optional auxiliary controls are inactive.

6. Electrical Connection to the Furnace

⚠ WARNING

Never connect a 120 volts AC circuit to the terminals of the Furnace Interlock. Use only the low voltage class 2 circuit of the furnace blower control.

For a furnace connected to cooling system:

On some older thermostat, energizing the "R" and "G" terminals at the furnace has the effect of energizing "Y" terminal at the thermostat and thereby turning on the cooling system. If you identify this type of thermostat, you must use the "Alternate Furnace Interlock Wiring". The "Standard Furnace Interlock" cannot be used and an additional control relay will have to be installed.

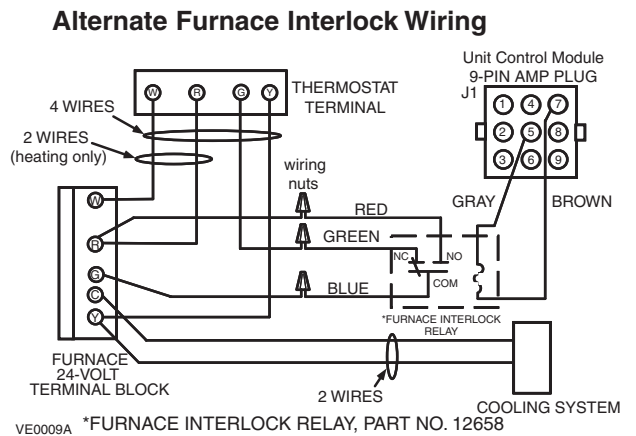
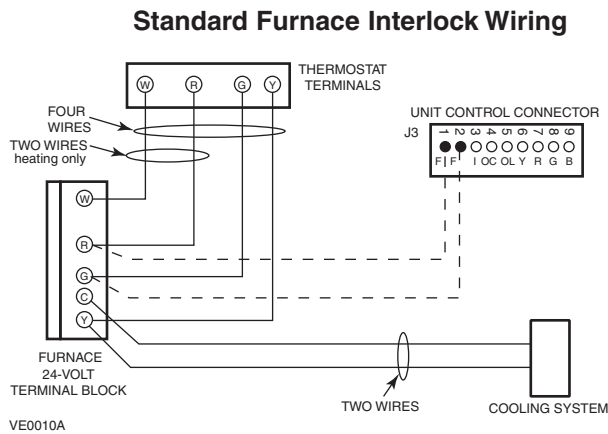

7. Furnace Interlock Types

The TII (*Timed Intermittent Interlock*) function consists in 2 modes: the standard mode and the special mode. Depending on the unit models, the electronic board terminal of the units has additional jumpers (see below for configuration).

VENMAR 1.8 HE AND VÄNEE 2000 HE STANDARD MODE

The standard mode is the default mode (the interlock function stay as it was). On standard mode, the jumper positions on terminal C and D keep them non-active:

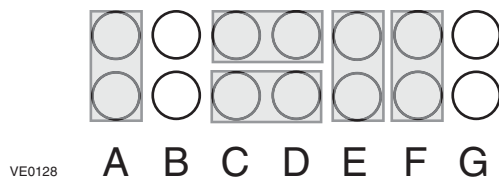

VENMAR 2.6 HE AND VÄNEE 3000 HE STANDARD MODE

The standard mode is the default mode (the interlock function stay as it was). On standard mode, the jumper position on upper terminals B and C keep them non-active:

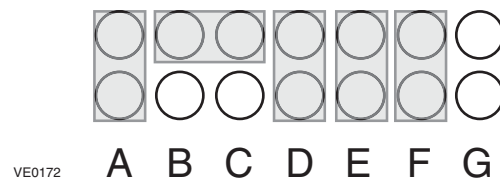

SPECIAL MODE (ALL UNITS)

The special mode drives the furnace interlock relay independently than the HRV operation. The K4 relay is activated for 10 minutes, and then is deactivated for a 20-minute period, no matter the HRV command, even if the HRV is stopped.

To perform the special mode, unplug the unit and change the jumper locations as shown below:

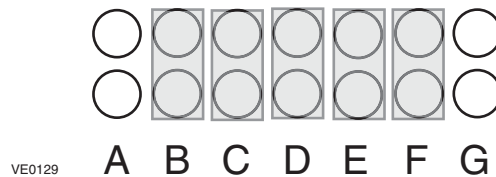

8. Wiring Diagram

⚠ WARNING

Risk of electrical shock. Before performing any maintenance or servicing, always disconnect the unit from its power source. This product employs overload protection (fuse). A blown fuse indicates an overload or short-circuit situation. If the fuse blows, unplug the product from the outlet. Replace the fuse as per the servicing instructions (follow product marking for proper fuse rating) and check the product. If the replacement fuse blows, a short-circuit may be present and the product should be discarded or returned to an authorized service facility for examination and/or repair.

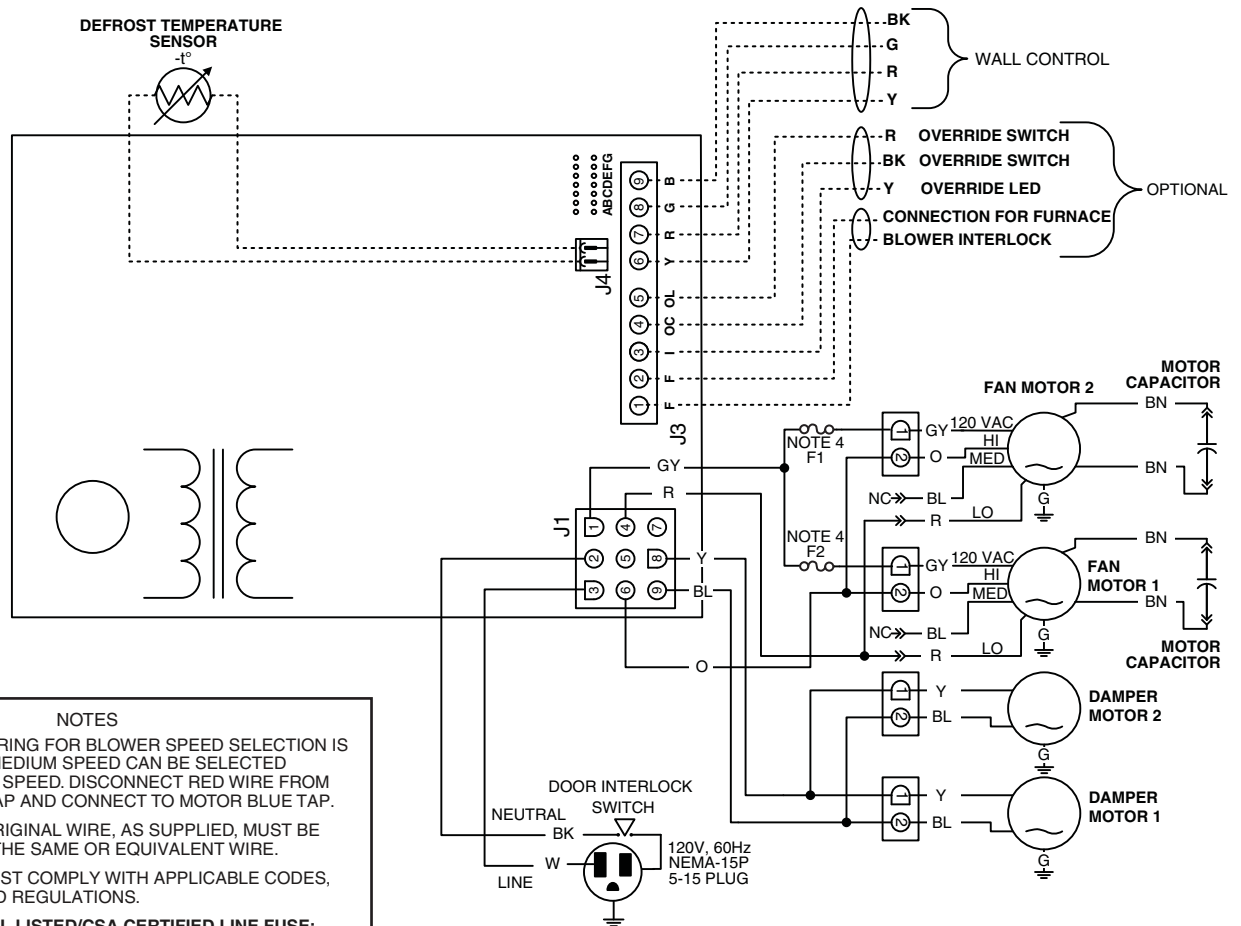

- NOTES**
- 1- FACTORY SET WIRING FOR BLOWER SPEED SELECTION IS HIGH AND LOW. MEDIUM SPEED CAN BE SELECTED INSTEAD OF LOW SPEED. DISCONNECT RED WIRE FROM MOTOR(S) RED TAP AND CONNECT TO MOTOR BLUE TAP.
 - 2- IF ANY OF THE ORIGINAL WIRE, AS SUPPLIED, MUST BE REPLACED, USE THE SAME OR EQUIVALENT WIRE.
 - 3- FIELD WIRING MUST COMPLY WITH APPLICABLE CODES, ORDINANCES AND REGULATIONS.
 - 4- **USE SPECIFIED UL LISTED/CSA CERTIFIED LINE FUSE:** LITTELFUSE (312 005), 3AG FAST-ACTING FUSE, 312/318 SERIES, RATING: 5A OR COOPER BUSSMANN (AGC-5), 3AG FAST-ACTING FUSE, AGC SERIES, RATING: 5A.

MODE	RELAY			
	K1	K2	K4*	K5
Intermittent	0	0	0	1
Exchange Low	1	0	1	0
Exchange High	1	1	1	0
Defrost Cycle	1	1	1	1
Off	0	0	0	1

0= Relay coil is de-energized/1= Relay coil is energized
 * On special mode, K4 is cycling 10 min. ON and 20 min. OFF

COLOR CODE	
BK	BLACK
BL	BLUE
BN	BROWN
G	GREEN
GY	GREY
NC	NO CONNECTION
O	ORANGE
R	RED
W	WHITE
Y	YELLOW

— LINE VOLTAGE
 CLASS 2 LOW VOLTAGE AND FIELD WIRING

Venmar 1.8 and vanEE 2000 JUMPER TABLE							TYPE	DEFROST TIME DEFROST/VENTILATION MINUTES		
JU1A	JU1B	JU1C	JU1D	JU1E	JU1F	JU1G		23°F	5°F	-22°F
IN	OUT	OUT	OUT	IN	IN	OUT	STANDARD MODE	6/60	6/32	6/20
IN	OUT	OUT	OUT	IN	OUT	OUT	EXTENDED DEFROST STANDARD MODE	10/30	10/20	10/15
OUT	IN	IN	IN	IN	IN	OUT	SPECIAL MODE	6/60	6/32	6/20
OUT	IN	IN	IN	IN	OUT	OUT	EXTENDED DEFROST SPECIAL MODE	10/30	10/20	10/15

Venmar 2.6 and vanEE 3000 JUMPER TABLE							TYPE	DEFROST TIME DEFROST/VENTILATION MINUTES		
JU1A	JU1B	JU1C	JU1D	JU1E	JU1F	JU1G		23°F	5°F	-22°F
IN	OUT	OUT	IN	IN	IN	OUT	STANDARD MODE	10/60	10/32	10/20
IN	OUT	OUT	IN	IN	OUT	OUT	EXTENDED DEFROST STANDARD MODE	10/30	10/20	10/15
OUT	IN	IN	IN	IN	IN	OUT	SPECIAL MODE	6/60	6/32	6/20
OUT	IN	IN	IN	IN	OUT	OUT	EXTENDED DEFROST SPECIAL MODE	10/30	10/20	10/15

9. Air Flow Balancing

What you Need to Balance the Unit

- A magnehelic gauge capable of measuring 0 to 0.25 inches water gauge (0 to 62.5 Pa) and 2 plastic tubes.
- Two flow collars (the size will vary depending on duct diameter).

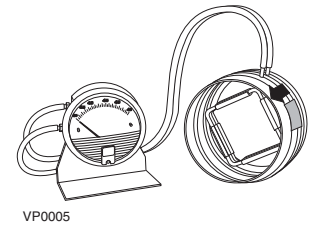

flow collar

Preliminary Stages for Balancing the Unit

Seal all the unit ductwork with tape. Close all windows and doors. Turn off all exhaust devices such as: range hoods, dryers and bathroom fans. Make sure balancing dampers are fully opened (F and G in figure below).

Choose appropriate locations for the 2 flow collars according to figure below :

- On the exhaust air duct (first measuring location, A)
- On the fresh air distribution duct (second measuring location, B)
- At least 36" (914 mm) away from the unit; at least 12" (304 mm) before or after a 90° elbow; at least 12" (304 mm) away from a register.

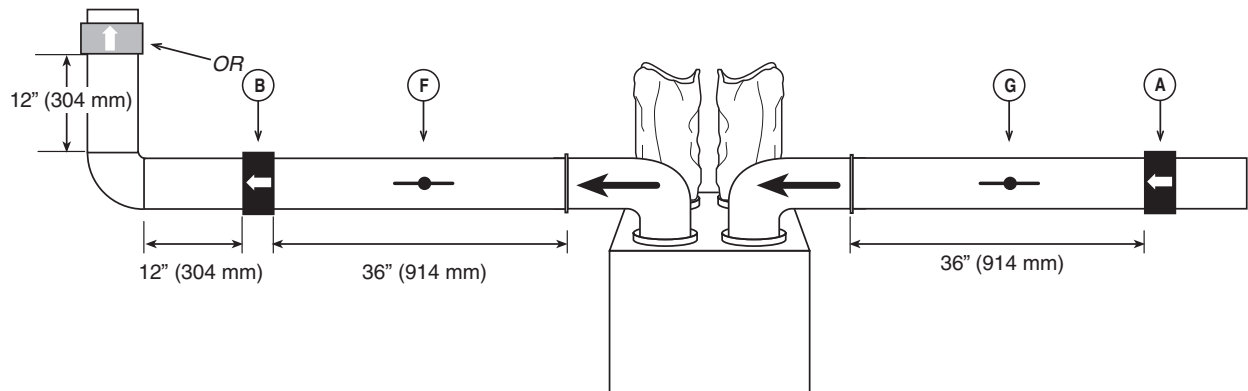

NOTE: To get the best ventilation performance from Venmar 2.6 HE and vänEE 3000 HE, refer to Point 4.5.2 on page 11.

Installation of Flow Collars

Insert the flow collars in the duct at each location (A and B on figure above). Make sure their arrows are pointing in the direction of the airflow. Tape collars in place temporarily.

Balancing procedure

1. Set the unit to high speed.
Make sure that the furnace blower is ON if the installation is in any way connected to the ductwork of the cold air return. If not leave furnace blower OFF.
If the outside temperature is below 0°C / 32°F, make sure the unit is not running in defrost while balancing. (By waiting 10 minutes after plugging the unit in, you are assured that the unit is not in a defrost cycle.)

2. Place the magnehelic gauge on a level surface and adjust it to zero.

3. Connect tubing from gauge to flow collar in exhaust air stream (location A in figure above).
Be sure to connect the tubes to their appropriate *high / low* fitting. If the gauge reading drops to below zero, reverse the tubing connections.

NOTE: It is better to start with the exhaust air flow reading because the exhaust typically has more restriction than the fresh air, especially in cases of fully ducted and exhaust ducted installations.

Hold or place the magnehelic gauge upright and level. Record the reading.

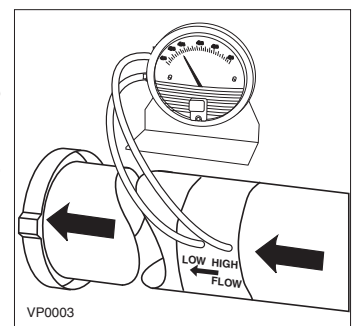

9. Air Flow Balancing (cont'd)

Balancing procedure (cont'd)

4. Move tubing to the other side of the unit (location B in figure on page 17) and note reading. Adjust the fresh air balancing damper F until the reading at B is approximately the same as the reading at A.

If the reading at B is less than the reading at A then go back and adjust the exhaust balancing damper G to equal the fresh air flow.

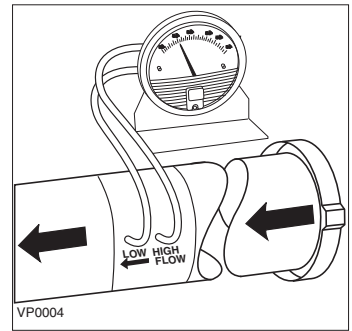

5. Remove flow collars and reconnect the duct, then, seal with duct tape. Write the required airflow information on a label and stick it near the unit for future reference: (date, maximum speed airflows, your name and phone number and business address).

NOTES:

- Most flow collar kits provide a conversion chart situated on the collar which enables you to convert magnehelic gauge readings to equivalent cfm values.
- A difference of ± 10 cfm (± 0.015 inches water gauge) between the 2 readings is considered balanced.
- If you are using only one flow collar, then, after completing the first reading, transfer this measuring device to the other side of the unit and take the second reading.

10. Maintenance

WARNING

Risk of electric shock. Before performing any maintenance or servicing, always disconnect the unit from its power source.

10.1 Regular Maintenance

- 1) Motor: The motor is factory lubricated for life. Lubricating the bearings is not recommended.

CAUTION

Because the unit is suspended, two people are recommended to remove or install the heat recovery core. Do not hold the heat recovery core using its plastic extrusions as handles.

- 2) The heat recovery core must be handled with care. We recommend that it be washed once a year, following the season of most intense use, in order to insure maximum efficiency of the plastic partitions. Allow the heat recovery core to soak for 3 hours in a solution of warm water and mild soap. Rinse under a heavy stream of water.
- 3) The air filters are washable. Under normal conditions, we recommend that they be washed every 3 months. Use a vacuum cleaner to remove the heaviest portion of accumulated dust. Then wash in lukewarm water.

CAUTION

Hot water and a strong detergent will damage the heat recovery core.

- 4) Regularly check the screen on the exterior intake hood and clean when necessary. Also check during very cold weather because ice may grow on the screen located at the exterior intake hood.

CAUTION

Even a partial blocking of this air vent could cause the unit to malfunction.



10.2 Prolonged Maintenance

Annual service should include:

- 1) Cleaning filters, heat recovery core and the exterior air intake/exhaust hood.
- 2) Cleaning the wheels and the blower blades.
- 3) Cleaning the condensation tray with soapy water (make certain that the drain is not clogged).
- 4) Running the system and checking the different operating modes.
- 5) Measuring and calibrating rates of flow using the procedure descriptions in Section 9.

11. Troubleshooting

NOTE: Inspect the unit before proceeding with these steps.

Problems	Possible causes	You should try this
1. The error code E1 is displayed on Platinum or Altitude wall control screen.	<ul style="list-style-type: none"> The wires may be in reverse position. 	<ul style="list-style-type: none"> Ensure that the color coded wires have been connected to their appropriate places.
2. There is no outside temperature displayed   on Platinum or Altitude wall control screen.	<ul style="list-style-type: none"> The unit thermistor is defective. 	<ul style="list-style-type: none"> Replace the unit thermistor. <p>NOTE: At his very start-up or after a power failure, it takes some minutes before the outside temperature appears on screen. The delay duration depends on which operation mode the wall control is set. The shortest delay is obtained when the wall control is set on MIN or MAX in VENT Mode.</p>
3. Altitude or Platinum wall control screen alternates between normal display and E3.	<ul style="list-style-type: none"> Short power failure may affect the electronic circuit. The on board thermistor is defective. 	<ul style="list-style-type: none"> Wait 24 hours; E3 will disappear and wall control screen will display normally. If after 24 hours the control screen still alternates between normal display and E3, replace the Altitude or Platinum wall control.
4. Altitude or Platinum wall control screen alternates between normal display and E4.	<ul style="list-style-type: none"> Short power failure may affect the electronic circuit. The on board humidity sensor is defective. 	<ul style="list-style-type: none"> Wait 24 hours; E4 will disappear and wall control screen will display normally. If after 24 hours the control screen still alternates between normal display and E4, replace the Altitude or Platinum wall control.
5. Unit does not work.	<ul style="list-style-type: none"> The circuit board may be defective. 	<ul style="list-style-type: none"> Unplug the unit. Disconnect the main control and the optional(s) control(s) (if need be). Jump B and G terminals. Plug the unit. If the motor runs on high speed and the damper opens, the circuit board is not defective.
6. One motor does not work	<ul style="list-style-type: none"> The fan motor fuse F1 or F2 may be blown. 	<ul style="list-style-type: none"> Unplug the unit. Check if the fuse is blown on both fan motor GREY wire (the strand is broken). If it is blown, replace the fuse according to the specifications on wiring diagram.
7. The damper actuator does not work.	<ul style="list-style-type: none"> The 9-pin connector may have a loose connection. The damper actuator may be defective. The circuit board may be defective. 	<ul style="list-style-type: none"> Unplug the unit and check to make sure all the crimp connections are secured. Check the damper actuator connections as well. Feed 120 V directly to the damper actuator. If the problem persists, replace the damper actuator. Replace the circuit board if the problem is not solved by the above.

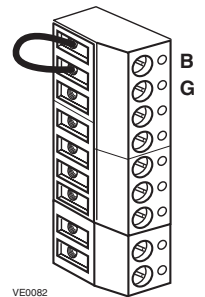

11. Troubleshooting (cont'd)

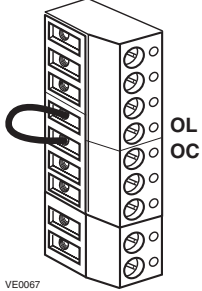
Problems	Possible causes	You should try this
8. The wall control does not work.	<ul style="list-style-type: none"> • TII mode is activated. • The wires may be in reverse position. • The wires may be broken. • There may be a short-circuit. • The wire in the wall OR the wall control may be defective. • The circuit board may be defective. 	<ul style="list-style-type: none"> • If the outside temperature is below -15°C (5°F), then the TII mode is probably activated. (See Section 7.) • Ensure that the color coded wires have been connected to their appropriate places. • Inspect every wire and replace any that are damaged. • With the help of a multimeter, check for continuity. • Remove the wall control and test it right beside the unit using another shorter wirer. If the wall control works there, change the wire. If it does not, change the wall control. • If the second wall control does not solve the problem, then replace the circuit board.
9. The 20/40/60-minute push-button timer does not work OR its indicator light does not stay on.	<ul style="list-style-type: none"> • The switch may be defective. 	<ul style="list-style-type: none"> • Unplug the unit. Disconnect the main control and the optional control(s) (if need be). Jump the OL and OC terminals. Plug the unit. If the unit switches to high speed, replace the switch.
		 <p>VE0067</p>
10. The defrost cycle does not work (the fresh air duct is frozen OR the fresh air distributed is very cold).	<ul style="list-style-type: none"> • Ice deposits may be hindering the damper operation. • The damper rod or the port damper itself may be broken. • The damper actuator may be defective. • The circuit board may be defective. • The thermistor may be defective. 	<ul style="list-style-type: none"> • Remove the ice. • Inspect these parts and replace if necessary. • Plug in the unit and select “MIN” or “MAX”. Press the door switch and see if the port damper opens. If it doesn’t open, feed 120 V directly to the damper actuator. If the port damper still does not open, replace the damper actuator. • Unplug the unit. Unplug the defrost sensor wire (see J4 on wiring diagram, Section 8). Plug the unit back in. Select “MIN” and make sure the unit is adjusted for low speed operation (turn all dehumidistats maximum counterclockwise). Wait 3 minutes. The unit should switch to high speed and the damper at the fresh air intake port should close (defrost mode). If it does not happen, then replace the circuit board. • If the defrost mode works well after having disconnecting the thermistor wire (above test), this means the thermistor is probably defective. You should replace it.

12. References

- CSA, Standard F326, “Residential Mechanical Ventilation Systems”.
- NRCC, “National Building Code” 1995 edition.
- HRAI, “Desing and installation Manual for Residential Mechanical Ventilation Systems”, 1987 edition.
- HRAI, “Installation Manual for Heat Recovery Ventilators”, 1987 edition.
- CSA Standard C444-M887, “Installation requirements for Heat Recovery Ventilators”.
- ASRHAE 1984 Systems Handbook, chapter 11, “Air Distribution Design for Small Heating and Cooling Systems”.